

Development of primary reference gas mixtures of 18 volatile organic compounds in hazardous air pollutants (5 nmol/mol level) and their analytical methods

Ji Hwan Kang^{1,2}, Yong Doo Kim¹, Jinhong Lee², and Sangil Lee^{3,4,*}

¹Gas Metrology Group, Korea Research Institute of Standards and Science (KRISS), 267, Gajeong-ro, Yuseong-gu, Daejeon 34113, Korea

²Department of Environmental Engineering, Chungnam National University, 99, Daehak-ro, Yuseong-gu, Daejeon 34134, Korea

³Division of Chemical and Biological Metrology, Korea Research Institute of Standards and Science (KRISS), 267, Gajeong-ro, Yuseong-gu, Daejeon 34113, Korea

⁴Science of Measurement, University of Science and Technology, 217, Gajeong-ro, Yuseong-gu, Daejeon 34113, Korea

(Received June 7, 2021; Revised July 19, 2021; Accepted July 2, 2021)

Abstract: Volatile organic compounds (VOCs) in hazardous air pollutants (HAPs) have been regulated by the Air Pollution Control Act (1978) and their atmospheric concentrations have been monitored in 39 monitor sites in Korea. However, measurement standards of volatile organic compounds (VOCs) in HAPs at ambient levels have not been established in Korea. Primary reference gas mixtures (measurement standards) at ambient levels are required for accurately monitoring atmospheric VOCs in HAPs and managing their emissions. In this study, primary reference gas mixtures (PRMs) at 5 nmol/mol were developed in order to establish primary national standards of VOCs in HAPs at ambient levels. Primary reference gas mixtures (PRMs) were prepared in pressurized aluminum cylinders with special internal surface treatment using gravimetric method. Analytical methods using gas chromatography-flame ionization detector (GC-FID) coupled with a cryogenic pre-concentrator were also developed to verify the consistency of gravimetrically prepared HAP VOCs PRMs. Three different columns installed in the GC-FID were evaluated and compared for the retention times and separation of eighteen target components in a chromatogram. Results show that the HAP VOCs PRMs at 5 nmol/mol were consistent within a relative expanded uncertainty ($k=2$) of less than 3 % except acrylonitrile (less than 6 %) and the 18 VOCs were stable for 1 year within their associated uncertainties.

Key words: HAPs, VOCs, Primary reference gas mixture, Standards

1. Introduction

The Organization for Economic Cooperation and Development (OECD) has emphasized in its environ-

mental prospects towards 2050 that there is an urgent need to mitigate the adverse environmental impact of climate change and air pollution.¹ With this, developed countries have recognized the severe

★ Corresponding author

Phone : +82-(0)42-868-5020 Fax : +82-(0)42-868-5800

E-mail : slee@kriss.re.kr

This is an open access article distributed under the terms of the Creative Commons Attribution Non-Commercial License (<http://creativecommons.org/licenses/by-nc/3.0>) which permits unrestricted non-commercial use, distribution, and reproduction in any medium, provided the original work is properly cited.

impact of the emissions of air pollutants on the environment and human health and have thus been monitoring air pollutants.²⁻³ However, the levels of air pollutants in cities have steadily increased due to transportation, industrialization, and population increase.⁴ Therefore, the policies to enhance the lifestyle and quality of life of humans should reflect the need to improve the air quality to protect human health against the sources of air pollution.⁵ Meanwhile, the OECD defines hazardous air pollutants (HAPs) as air pollutants predicted to cause irrevocable damage such as diseases or death.⁶ In the Clean Air Conservation Act in South Korea, certain air pollutants are defined as materials that may directly or indirectly harm humans or animals and plants.⁷ As such, although the concentrations of HAPs in the atmosphere are at nmol/mol levels,⁸⁻⁹ even the trace amounts make significant negative impact on humans as well as animals and plants due to the high toxicities and carcinogenicities.¹⁰⁻¹¹ It is thus important to measure accurately atmospheric HAPs at ambient levels; however, the respective measurement standards for numerous volatile organic compounds (VOCs) including HAPs have not been definitely established in South Korea.¹² The Clean Air Conservation Act defined 16 air pollutants as specific hazardous air pollutants in 1978, which was then revised to include 35 compounds in 2019.⁷ In relation to this, the Korea Ministry of Environment and the National Institute of Environmental Research have installed and operated a network of HAPs monitoring stations in urban areas and major industrial complexes with a population of greater than half a million. Thirty four air pollutants such as 18 VOCs and 16 polycyclic aromatic hydrocarbons (PAHs) have been measured in HAPs monitoring stations.¹³ The 18 HAP VOCs monitored at these stations are as follows: benzene, toluene, ethylbenzene, *m*-xylene, *p*-xylene, styrene, *o*-xylene, chloroform, methylchloroform, trichloroethylene, tetrachloroethylene, 1,1-dichloroethane, carbon tetrachloride, 1,3-butadiene, dichloromethane, vinyl chloride, 1,2-dichloroethane, and acrylonitrile. It has been reported that the ambient levels of HAP VOCs are in the range of 0.5-25 nmol/mol.¹³ Thus, it

is important to develop primary reference gas mixtures (PRMs) at nmol/mol levels for accurately monitoring ambient HAP VOCs and establishing the metrological traceability of the measurement results. The Korea Research Institute of Standards and Science has developed HAP VOCs PRMs (14 compounds) at 1 μ mol/mol with a relative expanded uncertainty of 0.7% ($k=2$) in 2015.¹⁴ In addition, prior to developing HAP VOCs PRMs at 5 nmol/mol (18 components), the short-term stability (physical adsorption loss onto cylinder internal surface) of 18 compounds of HAP VOCs at 5 nmol/mol level has been evaluated.¹⁵

In this study, analytical methods using a gas chromatography-flame ionization detector (GC-FID) coupled with a cryogenic pre-concentrator were developed to verify HAP VOCs PRMs at 5 nmol/mol level. For this, three different GC columns were evaluated in terms of GC retention time and peak separation. In addition, HAP VOCs PRMs at 5 nmol/mol were prepared in aluminum cylinders with a special internal surface treatment using gravimetric method (ISO 6142-1)¹⁶ and their uncertainties were estimated.

2. Materials and Methods

2.1. Reagents and apparatus

2.1.1. Analytical instruments and materials

GC-FID (7890, Agilent, USA) was used to analyze samples at μ mol/mol whereas samples at nmol/mol were analyzed using GC-FID (6890, Agilent, USA) coupled with a cryogenic pre-concentrator (7200, Entech Instruments Inc., USA). A cold trap with glass beads and tenax TA (T4, Entech Instruments Inc., USA) was installed in the pre-concentrator. In order to minimize the adsorption loss of samples at nmol/mol, pressure regulators (Swagelok, USA) and metal sample tubes (Swagelok, USA) with SilcoNert coatings were used for introducing samples from cylinders to GC-FID. Two types of cylinders were used for developing HAP VOCs PRMs: aluminum cylinders without special internal surface treatment (Luxfer, UK) for samples at μ mol/mol and aluminum cylinders with special internal surface treatment (Experis,

Air Products, Belgium) for samples at nmol/mol. Three different GC columns, such as CP-Sil 5CB ($60\text{ m} \times 0.32\text{ mm} \times 5\text{ }\mu\text{m}$, Agilent, USA), DB-1 ($60\text{ m} \times 0.32\text{ mm} \times 1\text{ }\mu\text{m}$, Agilent, USA), and VOCOL ($60\text{ m} \times 0.32\text{ mm} \times 5\text{ }\mu\text{m}$, Supelco, USA), were evaluated and compared in terms of GC-FID retention time and peak separation of each component of the HAP VOCs.

2.2. Methods

2.2.1. Analysis of samples at nmol/mol

An analytical system for PRMs at nmol/mol is described in Fig. 1. A gas sample is pulled into system based on pressure difference between the vacuum chamber of the cryogenic pre-concentrator and the sample. The pre-concentrator can be programmable to control a specific sample flow and volume (the maximum sample volume: 1 L). The sample injection port of the cryogenic pre-concentrator (eight port valves) stays closed (with the inside of the pre-concentrator in a vacuum), and upon the injection of

the sample, one of the port valves opens to allow the sample to be pulled into the cold trap based on the aforementioned pressure difference. A direction connection between sample cylinders and the pre-concentrator makes pressurized gas sample to be injected into the pre-concentrator so that a constant volume of gas sample cannot be trapped during analysis, leading to increased uncertainties in analytical repeatability and reproducibility. In order to reduce sample pressure, an automated valve controller (HDA021S, Hyo shin electric, Korea) with solenoid valves was used for analysis as shown in Fig. 1. The automated valve controller, by opening a solenoid valve, allows the discharge of any excess sample flow more than a preset sample flow injected into the pre-concentrator. Thus, a similar amount of gas sample at each injection is adsorbed in the cold trap which results in improving analytical repeatability and reproducibility, and ultimately reduce analytical uncertainties. In addition, by opening the solenoid valves, the continuous sample flow makes the internal

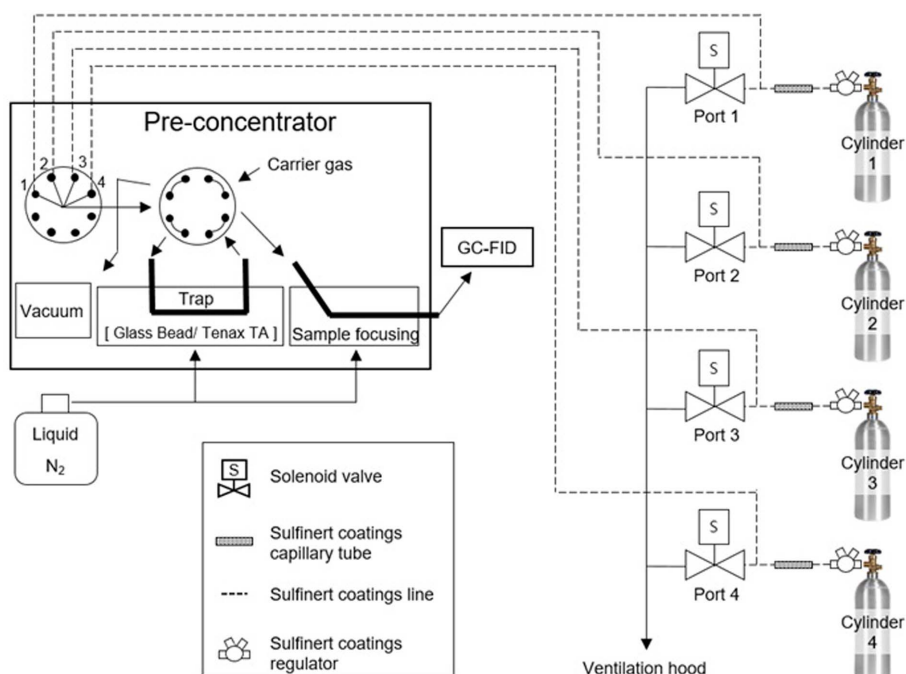

Fig. 1. Schematic diagram of an automated cryogenic pre-concentrator and sample injection system for analyzing HAP VOCs at nmol/mol.

surface of the metal sample tube passivated during analysis. A capillary tube with SilcoNert coating (Swagelok, USA) is connected to the pressure regulator to reduce sample flow. The analytical conditions of the cryogenic pre-concentrator for HAP VOCs PRMs at 5 nmol/mol are presented in *Table 1*. For each GC injection, a sample volume of 950 μ L was trapped at a flow rate of 90 mL/min and then focused for 4 minutes at the third trap (M3).

2.2.2. Preparation of HAP VOCs PRMs

A hierarchy of gravimetric preparation of HAP VOCs PRMs at 5 nmol/mol is shown in *Fig. 2*. The PRMs were prepared through a four-step dilution process using high-purity nitrogen. First, each of the 18 components of the HAPs was prepared in 100–200 μ mol/mol. Next, the 18 components were mixed into three groups for preparing gas mixtures at 10 μ mol/mol and then all 18 components were mixed into a single cylinder to produce gas mixtures at 100 nmol/mol. Lastly, HAP VOCs PRMs at 5 nmol/mol were

Table 2. Analytical conditions of GC-FID used for analyzing HAPs VOCs PRMs at nmol/mol

Valve Box	100 °C
Inlets	200 °C (Split ratio 10:1)
Column	Flow 2 mL/min (He)
Oven	60 °C (30 min) \rightarrow 20 °C/min, 180 °C (6 min) 250 °C
Detectors	H ₂ : 40 mL/min Air: 400 mL/min Makeup flow (He): 20 mL/min

prepared by diluting high-purity nitrogen. The peak retention time of each component was determined using 18 gas mixtures of a single component at μ mol/mol with analytical conditions shown in *Table 2*. The same analytical conditions were used to analyze HAP VOCs PRMs at 5 nmol/mol in order to compare and evaluate the retention times and separation of GC-FID peaks for 18 components for three different columns aforementioned in the section 2.1.1.

Table 1. Analytical conditions of a cryogenic pre-concentrator used for analyzing HAP VOCs PRMs at nmol/mol

Trap Temp	M3	M2	M2 \rightarrow M3	Inject	Bake
Mod 2	-100 °C	-100 °C	220 °C		200 °C
Mod 2 Bulk	90 °C	100 °C			
Mod 3	-170 °C		-170 °C	120 °C	120 °C

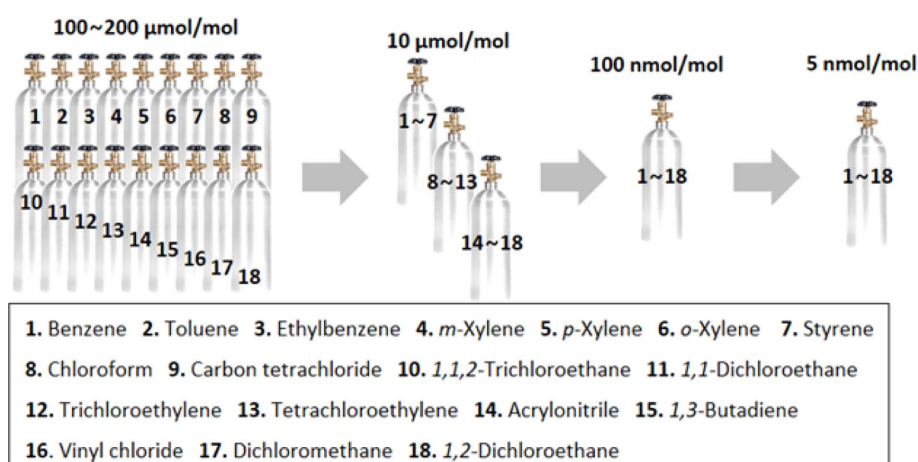

Fig. 2. A hierarchy of gravimetric preparation of primary reference gas mixtures of HAP VOCs PRMs at 5 nmol/mol.

2.2.3. Assessment of long-term stability of HAP VOCs PRMs at 5 nmol/mol

There are several methods to evaluate the long-term stability of PRMs. The first method is to simultaneously inject a component with verified long-term stability (e.g., propane, *n*-hexane, etc.) when PRMs are prepared for a target component.¹⁷⁻¹⁸ The long-term stability of a target component is assessed through linear regression analysis after monitoring the time-dependent ratio between a target component and a stable component. The second method is to use a dynamic dilution method in which PRMs at nmol/mol can be generated by diluting stable and traceable PRMs at $\mu\text{mol/mol}$.¹⁹ The long-term stability of a target component can be assessed by directly comparing PRMs in cylinders with newly generated gas mixtures (at nmol/mol) from the dynamic dilution method.¹⁸ Lastly, newly prepared PRMs in cylinders can be directly compared with off-the-shelf PRMs at a similar mole fraction.^{14,18} In this study, the third method was used to evaluate the long-term stability of HAP VOCs PRMs at 5 nmol/mol. For this, the PRMs prepared in September 2019 (off-the-shelf) were compared with the PRMs prepared in September 2020 in order to estimate the stability for one year. As shown in Eq. (1), the ratios of analytical sensitivities of PRMs (2020) and PRMs (2019) for each component can be calculated and used for evaluating the long-term stability.

$$R = \frac{S_{2019}}{S_{2020}} = \frac{P_{2019}/x_{2019}}{P_{2020}/x_{2020}} \quad (1)$$

In Eq. (1), S_{2019} and S_{2020} are analytical sensitivities, P_{2019} and P_{2020} are GC-FID peak areas, and x_{2019} and x_{2020} are mole fractions of PRMs. The combined standard uncertainties ($u(R)$) for the ratios (R) of analytical sensitivities between the two PRMs are calculated as in Eq. (2), where $u(x_{2020})$ are the standard gravimetric uncertainties of the PRMs (2020), and $u(P_{2019})$ and $u(P_{2020})$ are the standard analytical uncertainties of PRMs (2019) and PRMs (2020), respectively. The expanded uncertainties are calculated as in Eq. (3), where k is a coverage factor ($k=2$ at a level of confidence of about 95%).

$$u(R) = \sqrt{u^2(x_{2020}) + u^2(P_{2019}) + u^2(P_{2020})} \quad (2)$$

$$U(R) = k \times u(R) \quad (3)$$

2.2.4. Assessment of preparation uncertainties of HAP VOCs PRMs at 5 nmol/mol

HAP VOCs PRMs at 5 nmol/mol were prepared in four aluminum cylinders with special internal surface treatment (Cylinder No.: D517447, D517621, D600124, and D600130) by diluting HAP VOCs PRMs at 100 nmol/mol. The mole fractions (i.e., amount fractions) of the PRMs and their associated uncertainties were calculated according to ISO 6142-1 (2015)¹⁶ and the final standard preparation uncertainties ($u(x_{prep.})$) were estimated as shown in Eq. (4) by combining the standard gravimetric uncertainty ($u(x_{grav.})$) and standard verification uncertainty ($u(x_{ver.})$).

$$u(x_{prep.}) = \sqrt{u^2(x_{grav.}) + u^2(x_{ver.})} \quad (4)$$

Here, the standard gravimetric uncertainty ($u(x_{grav.})$) is the uncertainty in the measurement of the mass of the injected gas in the cylinder, and the standard verification uncertainty ($u(x_{ver.})$) is the uncertainty in the analysis for evaluating the consistency of the gravimetric preparation. The final preparation uncertainties (Table 3) were expressed as the relative expanded uncertainties ($U(x_{prep.})/x_{prep.} \times 100\%$) at a level of confidence of about 95%, $k = 2$. All uncertainties were propagated using the GUM Workbench (version 2.3.6.141, Metrodata GmbH, Germany).

3. Results and Discussion

3.1. Analysis of HAP VOCs PRMs at 5 nmol/mol using three different columns

GC-FID chromatograms resulted from analyzing HAP VOCs PRMs at 5 nmol/mol are presented in Fig. 3. As shown, the order of the retention times of 18 peaks were identical for the DB-1 and CP-Sil 5CB columns, whereas for the VOCOL column, several components (e.g., 3. acrylonitrile and 4. dichloromethane) exhibited varying retention times. These variations were mainly due to the difference in polarity of column materials; the DB-1 and CP-Sil 5CB columns

Table 3. Amount fractions (mole fractions) and their relative expanded uncertainties (U , $k=2$) of HAP VOCs PRMs at 5 nmol/mol

Cylinder number	Component	Amount fraction (nmol/mol)	U (%) ($k=2$)	Component	Amount fraction (nmol/mol)	U (%) ($k=2$)
D517447	vinyl chloride	5.33	1.2	trichloroethylene	4.95	1.0
D517621		5.04	1.2		4.90	1.0
D600124		5.90	1.1		5.06	0.9
D600130		5.95	1.0		5.26	0.9
D517447	1,3-butadiene	5.41	1.2	1,1,2-trichloroethane	5.25	1.0
D517621		5.12	1.1		5.21	1.0
D600124		5.21	1.1		4.99	0.9
D600130		5.26	1.0		5.19	0.9
D517447	acrylonitrile	5.40	5.4	toluene	5.76	0.9
D517621		5.10	5.8		5.63	0.9
D600124		5.12	5.7		5.83	0.8
D600130		5.17	5.6		5.87	0.8
D517447	dichloromethane	5.41	1.0	tetrachloroethylene	5.39	1.2
D517621		5.12	1.1		5.34	1.1
D600124		5.09	1.0		4.90	1.1
D600130		5.13	0.9		5.10	1.1
D517447	1,1-dichloroethane	5.09	1.1	ethylbenzene	5.35	1.2
D517621		5.04	1.1		5.23	1.6
D600124		4.88	1.0		5.24	1.1
D600130		5.08	0.9		5.28	1.1
D517447	chloroform	5.09	1.1	<i>m</i> -xylene	5.32	1.3
D517621		5.04	1.2		5.21	1.3
D600124		4.92	1.0		5.36	1.3
D600130		5.12	0.9		5.40	1.3
D517447	1,2-dichloroethane	5.40	1.1	<i>p</i> -xylene	5.20	1.4
D517621		5.10	1.0		5.08	1.3
D600124		5.96	0.9		5.34	1.3
D600130		6.01	0.9		5.38	1.3
D517447	benzene	5.36	0.9	styrene	5.34	1.3
D517621		5.24	0.9		5.22	1.2
D600124		5.45	0.9		5.41	1.2
D600130		5.48	0.8		5.45	1.2
D517447	carbon tetrachloride	5.11	3.0	<i>o</i> -xylene	5.28	1.4
D517621		5.06	3.0		5.17	1.4
D600124		4.93	3.0		5.19	1.4
D600130		5.12	2.9		5.23	1.8

non-polar, and the VOCOL column is semi-polar. In addition, for the DB-1 and CP-Sil 5CB columns, all components with the exception of *m,p*-xylene were separated; however, for the VOCOL column, certain components (1. vinyl chloride ↔ 2. 1,3-butadiene / 7. 1,2-dichloroethane ↔ 8. benzene) were not separated.

It was not successful to separate some co-eluted peaks even by adjusting GC-FID oven temperature or flow rate for the VOCOL column. It was noteworthy that, for the DB-1 column, (15. *m*-xylene) and (16. *p*-xylene) appeared to be partially separated. It is generally the case for the DB-1 column that (15. *m*-

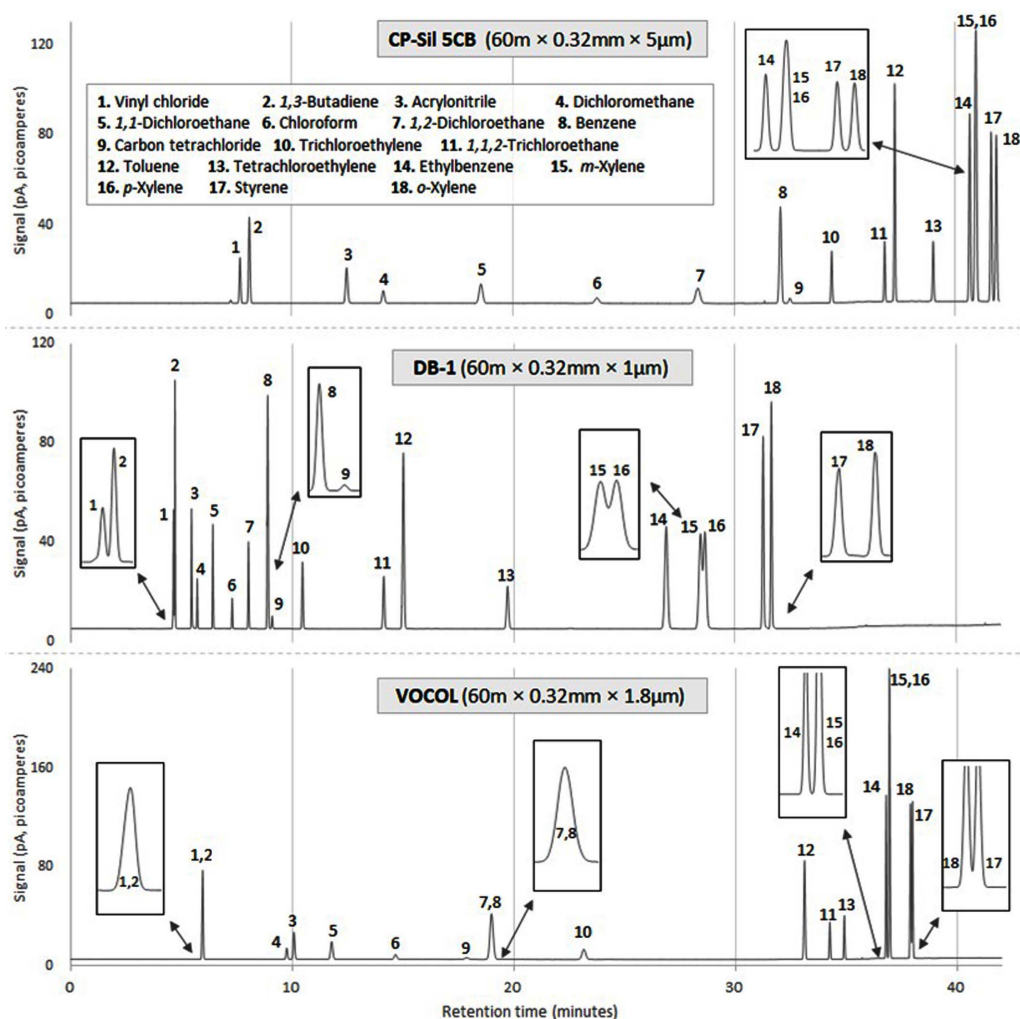

Fig. 3. Chromatograms of GC-FID with cryogenic pre-concentrator for HAP VOCs PRMs at 5 nmol/mol.

xylene) and (16. *p*-xylene) are not separated, as in the case of the CP-Sil 5CB column,²⁰ and the partial separation is thought to be due to the characteristics of the cryogenic pre-concentrator (e.g., the focusing time of M3 trap). For the DB-1 column, further studies need to be conducted to evaluate whether the complete separation of (15. *m*-xylene) and (16. *p*-xylene) is possible for analyzing HAP VOCs at 5 nmol/mol.

3.2. Assessment of long-term stability of HAP VOCs PRMs at 5 nmol/mol

Results from the long-term stability of the HAP VOCs PRMs at 5 nmol/mol are presented in Fig. 4.

The PRM with a cylinder number of D517447 was prepared in 2019, whereas the PRMs with a cylinder number of both D877396 and D877398 were prepared in 2020. In addition, the ratios shown in Fig. 4 were estimated using Eq. (1) and the PRM (D877398) was used to calculate the denominator in Eq. (1). The uncertainties of the ratios were estimated from 0.9 % for toluene to 3.0 % (at a level of confidence of about 95 %, $k = 2$) for carbon tetrachloride. As shown in Fig. 4, the ratios of all 18 components were consistent within their uncertainties indicating that all components were stable for one year within their associated uncertainties.

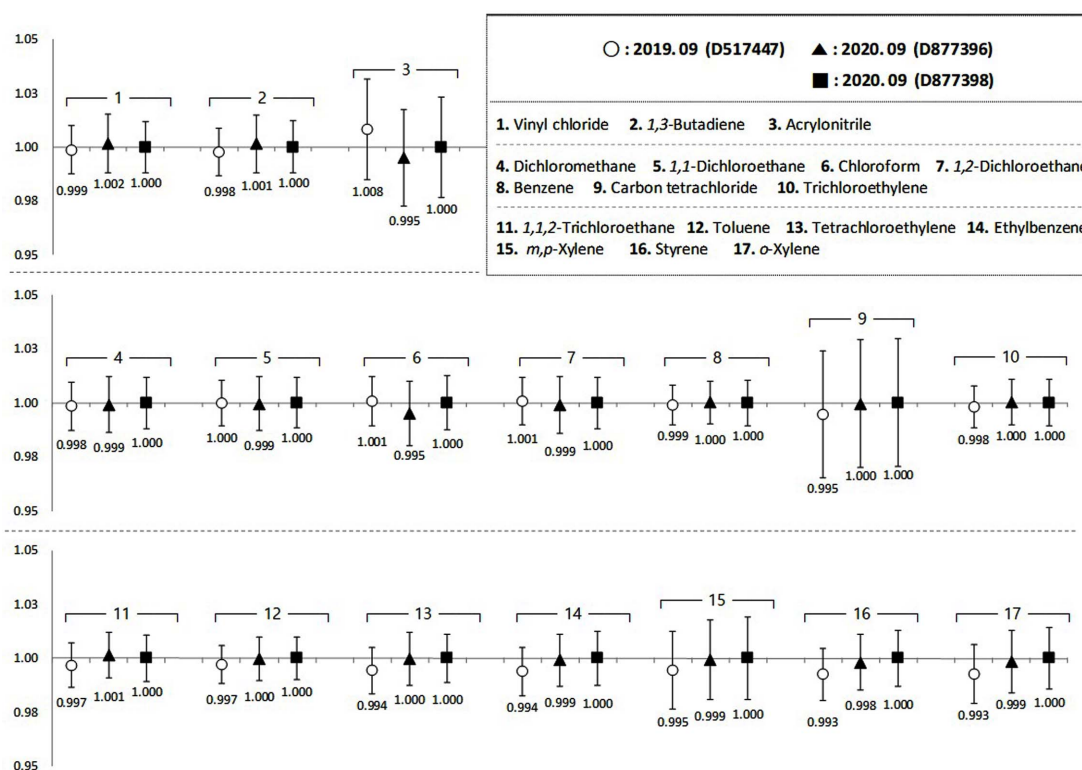

Fig. 4. Long-term stabilities of HAP VOCs PRMs at 5 nmol/mol (y axes are relative ratios of 2019 gas mixture' sensitivities to 2020 gas mixtures' sensitivities. Error bars represent expanded uncertainties ($k=2$)).

3.3. Assessment of consistency of gravimetric preparation of HAP VOCs PRMs at 5 nmol/mol

Table 3 presents the mole fractions and relative expanded uncertainties for HAP VOCs PRMs at 5 nmol/mol prepared in 2019. The consistency of the gravimetric preparation of four PRMs was verified by analyzing those against each other. As shown in Fig. 5, all components were consistent within their preparation uncertainties (Eq. (4)). The stabilities of PRMs also need to be taken into account for estimating the final preparation uncertainties of PRMs. There are two stability components such as short-term (i.e., physical adsorption loss onto cylinder internal surface) and long-term stability. The uncertainties of the long-term stability were neither calculated nor combined into the final preparation uncertainties since the long-term stability study showed that all 18 components were stable for one year. A previous study regarding the short-term stability showed that a

significant loss was found only for acrylonitrile whereas little loss was observed for the other 17 components.¹⁵ Thus, the uncertainties of the short-term stability were not combined into the final preparation uncertainties for the 17 components while the mole fractions of acrylonitrile were corrected to take account of the adsorption loss and their uncertainties were re-calculated by combining uncertainties from the short-term stability study. The preparation uncertainties of the 17 components of the HAP VOCs PRMs at 5 nmol/mol level varied from 0.8 % to 3.0 %, whereas for acrylonitrile, its uncertainties were about 6 % due to the adsorption loss to the cylinder internal surface.

4. Conclusions

This study aimed to find proper analytical methods for 18 components of HAP VOCs at nmol/mol and

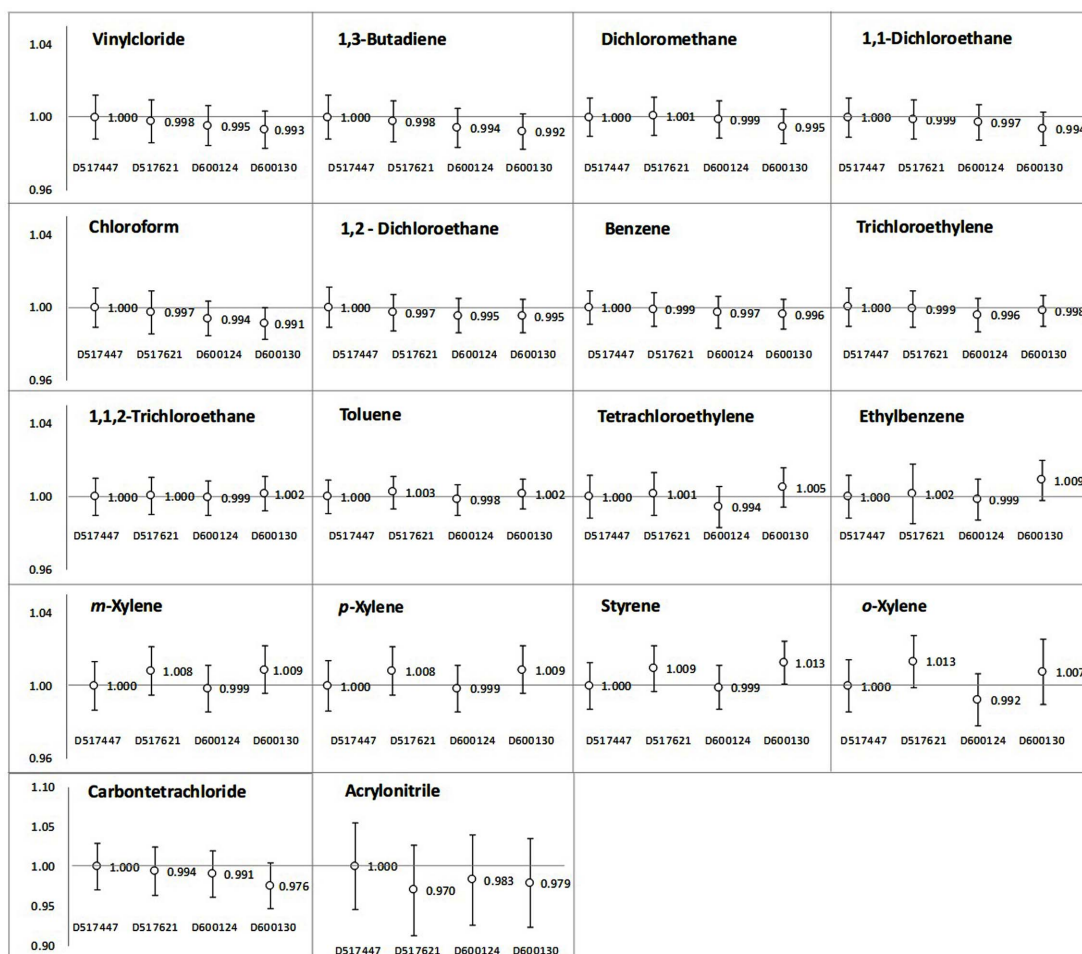

Fig. 5. Consistencies of gravimetric preparations of HAP VOCs PRMs at 5 nmol/mol (error bars represent expanded uncertainties ($k=2$). Ratios are relative ratios of sample sensitivities to reference sensitivities).

estimate the uncertainties of the gravimetric preparations of HAP VOCs PRMs at 5 nmol/mol. To analyze HAP VOCs samples at nmol/mol, proper analytical conditions for three different GC columns were developed and compared for GC-FID coupled with a cryogenic pre-concentrator. Results from the comparison showed that both CP-Sil 5CB and DB-1 columns were suitable for the analysis (although *m*-xylene was not completely separated from *p*-xylene), whereas there were significant limitations to separate GC peaks of certain components for the VOCOL column. For the complete separation of *m*-xylene or *p*-xylene, a different GC column such as the DB-

WAX should be used.²⁰ It was found that HAP VOCs PRMs at 5 nmol/mol was stable for one year, and further studies will be conducted periodically for additional long-term stability assessments. The preparation uncertainties of HAP VOCs PRMs prepared in aluminum cylinders with special internal surface treatment were estimated as approximately 3% ($k = 2$) except acrylonitrile; the uncertainties of acrylonitrile were estimated as about 6% due to the physical adsorption loss onto the cylinder internal surface.¹⁵

The dissemination of HAP VOCs PRMs at 5 nmol/mol developed in this study can contribute to the establishment of the metrological traceability and

the improvement of the reliability of HAP VOCs measurement results at hazardous air pollutants monitoring stations.

Acknowledgements

This work was supported by a grant (2018001860001) from the Korea Ministry of Environment under the Green Patrol Technologies Project: *Demonstration test for continuous automatic measuring device for harmful substances in Korea and oversea.*

References

1. Organization for Economic Cooperation and Development (OECD), 'OECD Environmental Outlook to 2050', https://www.oecd-ilibrary.org/environment/oecd-environmental-outlook-to-2050_9789264122246-en, Accessed 8 May 2021.
2. European Environment Agency (EEA), 'Air pollution. European Environment Agency', <https://www.eea.europa.eu/themes/air>, Accessed 8 May 2021.
3. US Environmental Protection Agency (US EPA), 'National Air Quality: Status and Trends of Key Air Pollutants', <https://www.epa.gov/air-trends>, Accessed 8 May 2021.
4. H. Mayer, *Atmos. Environ.*, **33**, 4029-4037 (1999).
5. M. Darçın, *Environ. Sci. Pollut. Res.*, **21**(3), 1954-1959 (2014).
6. Organization for Economic Cooperation and Development (OECD), 'Hazardous air pollutants', <https://stats.oecd.org/glossary/detail.asp?ID=1204>, Accessed 8 May 2021.
7. Korea Ministry of Environment (Korea MOE), 'Enforcement rule of Clean Air Conservation Act', <https://www.law.go.kr/LSW/lsLawLinkInfo.do?lsJoLnkSeq=1009298215&chrClsCd=010202&ancYnChk=0>, Accessed 8 May 2021.
8. A. S. Rosenbaum, D. A. Axelrad, T. J. Woodruff, Y. H. Wei, M. P. Ligocki and J. P. Cohen, *J. Air Waste Manag. Assoc.*, **49**, 1138-1152 (1999).
9. C. C. Travis and S. T. Hester, *Environ. Sci. Technol.*, **25**, 815-818 (1991).
10. M. Kampa and E. Castanas, *Environ. Pollut.*, **151**, 362-367 (2008).
11. D. W. Dockery and C. A. Pope, *Annu. Rev. Public Health.*, **15**, 107-132 (1994).
12. Y. K. Seo, S. H. Chung and S. O. Baek, *J. Korean Soc. Atmos. Environ.*, **27**(6), 734-745 (2011).
13. Korea Ministry of Environment (Korea MOE) and National Institute of Environmental Research (NIER), 'Air Pollution Measurement Installation Operating Instructions', p52/ p189, Jan 2021.
14. J. H. Kang, Y. D. Kim, M. E. Kim, J. H. Lee and S. Lee, *J. Korean Soc. Atmos. Environ.*, **34**(2), 331-341 (2018).
15. S. B. Jeon, Y. D. Kim, J. H. Kang and S. Lee, *J. Environ. Anal. Health Toxicol.*, **23**(1), 47-54 (2020).
16. International Organization for Standardization (ISO 6142-1), 'Gas analysis - Preparation of Calibration Gas Mixtures - Part 1: Gravimetric Method of Class I Mixtures', 2015.
17. G. C. Rhoderick, *Anal. Bioanal. Chem.*, **383**, 98-106 (2005).
18. M. E. Kim, J. H. Kang, Y. D. Kim, D. S. Lee and S. Lee, *Bull. Korean Chem. Soc.*, **39**(3), 305-312 (2018).
19. M. E. Kim, Y. D. Kim, J. H. Kang, G. S. Heo, D. S. Lee and S. Lee, *Talanta*, **150**, 516-524 (2016).
20. C. F. Poole and S. K. Poole, *J. Chromatogr. A*, **1184**, 254-280 (2008).

Authors' Position

Ji Hwan Kang : Senior Research Engineer / Graduate Student
 Yong Doo Kim : Principal Research Engineer
 Jinhong Lee : Professor
 Sangil Lee : Principal Research Scientist / Professor