

## Development of analytical method for the isotope purity of pure D<sub>2</sub> gas using high-precision magnetic sector mass spectrometer

Jinwoo Chang<sup>1,2</sup>, Jin Bok Lee<sup>1</sup>, Jin Seog Kim<sup>1</sup>, Jin-Hong Lee<sup>2</sup>, and Kiryong Hong<sup>1</sup> ★

<sup>1</sup>Gas Metrology Group, Division of Chemical and Biological Metrology, Korea Research Institute of Standards and Science, Daejeon 34113, Korea

<sup>2</sup>Department of Environmental Engineering, Chungnam National University, Daejeon 34134, Korea

(Received September 8, 2022; Revised October 5, 2022; Accepted October 7, 2022)

**Abstract:** Deuterium (D) is an isotope with one more neutron number than hydrogen (H). Heavy elements rarely change their chemical properties with little effect even if the number of neutrons increases, but low-mass elements change their vibration energy, diffusion rate, and reaction rate because the effect cannot be ignored, which is called an isotope effect. Recently, in the semiconductor and display industries, there is a trend to replace hydrogen gas (H<sub>2</sub>) with deuterium gas (D<sub>2</sub>) in order to improve process stability and product quality by using the isotope effect. In addition, as the demand for D<sub>2</sub> in industries increases, domestic gas producers are making efforts to produce and supply D<sub>2</sub> on their own. In the case of high purity D<sub>2</sub>, most of them are produced by electrolysis of heavy water (D<sub>2</sub>O), and among D<sub>2</sub>, hydrogen deuteride (HD) molecules are present as isotope impurities. Therefore, in order to maximize the isotope effect of hydrogen in the electronic industry, HD, which is an isotope impurity of D<sub>2</sub> used in the process, should be small amount. To this end, purity analysis of D<sub>2</sub> for industrial processing is essential. In this study, HD quantitative analysis of D<sub>2</sub> for high purity D<sub>2</sub> purity analysis was established and hydrogen isotope RM (Reference material) was developed. Since hydrogen isotopes are difficult to analyze with general gas analysis instrument, they were analyzed using a high-precision mass spectrometer (Gas/MS, Finnigan MAT271). High purity HD gas was injected into Gas/MS, sensitivity was determined by a signal according to pressure, and HD concentrations in two bottles of D<sub>2</sub> were quantified using the corresponding sensitivity. The amount fraction of HD in each D<sub>2</sub> was (4518 ± 275) μmol/mol, (2282 ± 144) μmol/mol. D<sub>2</sub>, which quantifies HD amount using the developed quantitative analysis method, will be manufactured with hydrogen isotope RM and distributed for quality management and maintenance of electronic industries and gas producers in the future.

**Key words:** Gas mass spectrometer #1, Hydrogen deuteride #2, Purity analysis #3, Reference material #4, Deuterium #5

### 1. Introduction

The mass of deuterium gas (D<sub>2</sub>) is approximately twofold higher than that of hydrogen gas (H<sub>2</sub>); thus,

differences in their kinetic rates, as well as the associated decrease in diffusion rate or reaction rate, may be expected.<sup>1</sup> These characteristics endow D<sub>2</sub> with several advantages, such as higher process stability

★ Corresponding author

Phone : +82-(0)42-868-5236 Fax : +82-(0)42-868-5344

E-mail : khong@kriss.re.kr

This is an open access article distributed under the terms of the Creative Commons Attribution Non-Commercial License (<http://creativecommons.org/licenses/by-nc/3.0>) which permits unrestricted non-commercial use, distribution, and reproduction in any medium, provided the original work is properly cited.

and a longer lifetime of product, compared with H<sub>2</sub>. In the semiconductor industry, H<sub>2</sub> is gradually being replaced with high-purity D<sub>2</sub> to enhance product quality because the use of D<sub>2</sub> reduces hot-carrier effects during annealing.<sup>2,3</sup> In the display industry, OLED devices incorporated with deuterium substitution compounds have been reported to show 20 % or greater improvements in lifetime compared with conventional devices.<sup>4,5</sup> In addition to its applications in the electronics industry, deuterium serves as a source material for nuclear fusion energy, which has gained much attention as a clean energy; deuterium substitution is often applied in pharmaceuticals to increase the retention time of active drug substances in the plasma.<sup>6</sup> The projected demand for D<sub>2</sub> across various fields has prompted numerous research efforts toward providing large amounts of high-purity deuterium. The D<sub>2</sub> used in South Korea accounts for over half of the entire global market; however, owing to the lack of a suitable D<sub>2</sub> production facility for industrial purposes, the country is entirely dependent on D<sub>2</sub> imports.<sup>7</sup> Several gas manufacturers in South Korea have sought to construct facilities for high-purity D<sub>2</sub> production. Most high-purity D<sub>2</sub> production technologies involve the electrolysis of heavy water (D<sub>2</sub>O); however, the D<sub>2</sub> produced via this approach includes hydrogen deuteride (HD), a hydrogen isotope, and H<sub>2</sub> as impurities.<sup>8,9</sup> When high amount fractions of these isotope impurities exist in D<sub>2</sub>, the advantages of the gas cannot be maximized owing to the isotope effect, and its use could lead to reduced process efficiency or low product quality. Thus, the isotope impurities in high-purity D<sub>2</sub> must be controlled to sufficiently low levels to ensure process stability and production efficiency. The production of high-quality D<sub>2</sub> requires the development of a reliable method for purity analysis to allow for the quantification of hydrogen isotopes in D<sub>2</sub>.<sup>10</sup> A reference material (RM) with clearly defined HD amount fractions should also be established to enable rapid analyses by manufacturers.

Most reference gases are produced via the gravimetric preparation method according to ISO 6142,<sup>11</sup> which requires knowledge of the accurate amount fractions of the critical impurities in the source gas. Hence,

analysis of the hydrogen isotope impurities in the source D<sub>2</sub> is necessary. Gas chromatography (GC), which is mainly used in gas analysis, is unsuitable for industrial-scale isotope analysis and difficult to perform in some conditions,<sup>12</sup> such as extremely low temperatures. Thus, a measurement method employing a suitable device is necessary to analyze hydrogen isotopes in high-purity D<sub>2</sub>, which would allow for quality control during high-purity D<sub>2</sub> production.

In this study, a novel method was developed using a high-precision mass spectrometer (Gas/MS, Finnigan MAT271) to quantify HD impurities in high-purity D<sub>2</sub>. An RM for hydrogen isotopes was then established by defining the HD amount fraction in D<sub>2</sub>.

## 2. Experimental

### 2.1. Reagents and apparatus

High-purity D<sub>2</sub> (99.995 %, Deokyang Co., Ltd., Republic of Korea), H<sub>2</sub> (99.999 %, Deokyang Co., Ltd., Republic of Korea), and HD (>97 %, Cambridge Isotope Laboratories, Inc., USA) were used in this study.

For the RM production cylinder, a Ni-Cr coated valve was attached to an Al cylinder (volume, 3 L). All Al cylinders were set to a vacuum state below  $1.0 \times 10^{-2}$  Pa using rotary and turbo molecular pumps in preparation for the production. During production, the Al cylinders were heated to 60 °C to remove water and impurities adsorbed in the cylinder interior.

### 2.2. Settings for the high-precision mass spectrometer

GC is the most widely used method of gas analysis because it can be applied to most gas types owing to the large number of detectors and columns are available. However, because the target gas should be separated from other gases in the column for accurate analysis, the method is difficult to use for analyzing isotopes, the chemical properties of which are highly similar. In particular, hydrogen isotopes, the targets in this study, require extremely low temperatures for separation, as well as a specially designed column<sup>12</sup>; moreover, the analysis is time consuming. Thus, GC

cannot be used by manufacturers for gas analysis.

In this study, a high-precision mass spectrometer was used to analyze hydrogen isotopes. The device used in this study was a single-focus, magnetic-sector type instrument equipped with a molecular flow gas injection system. This system is generally used by research institutes such as the Korea Research Institute of Standards and Science (KRISS), Istituto Nazionale di Ricerca Metrologica (INRiM), and Institute for Reference Materials and Measurements (IRMM) to determine isotope ratios and has recently been applied to analyze the isotope ratio of inert gases such as Ne

and He.<sup>13-15</sup> Unlike a gas chromatograph, this instrument requires only trace amounts of the sample and a short analysis time. In addition, the excellent resolution of the device allows for the adequate separation of hydrogen isotopes, thereby enabling the simultaneous analyses of H<sub>2</sub>, HD, and D<sub>2</sub>.

Figs. 1 and 2 show schematics of the sample inlet of the instrument and the system components from the ionization chamber to the detector, respectively. The gas sample is injected into the instrument through the inlet. The Gas/MS is designed so that the gas enters the ionization chamber as a molecular flow through 10 holes measuring 10 μm size in an antechamber.<sup>16</sup> The gas sample is ionized so that the gas molecules transform into gas ions under a constant emission current in the segment composed of tungsten filaments. The ionized particles are subjected to an acceleration voltage so that they can pass through the magnetic sector with a magnetic field. The magnet in the magnetic sector is designed to have a 90° angle to refract the ionized particles; because each particle exhibits a unique refractive index, the particles are separated according to their mass-to-charge ratio (m/z) upon reaching the detector. At the faraday cup, which functions as the detector, the intensity is measured in units of volts (V) or millivolts (mV).

Table 1 presents the main settings of the mass spectrometer. The pressure of the interior chamber

### MAT 271 Inlet system

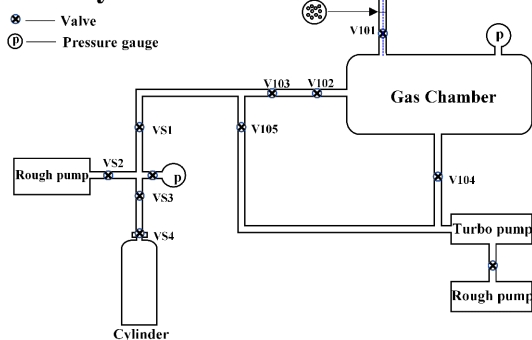

Fig. 1. MAT 271 Inlet system. The injection pressure can be adjusted by opening and closing each valve and is injected into the ionization part from the gas chamber.

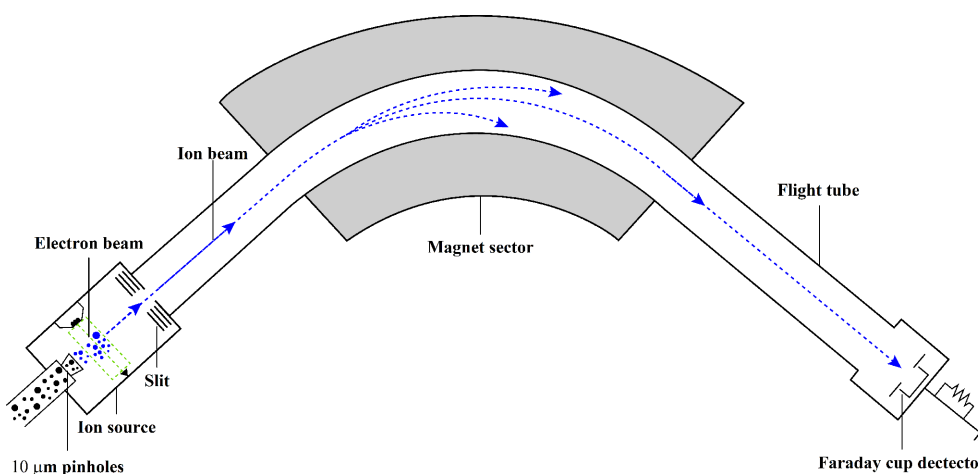

Fig. 2. Schematics of MAT271 gas mass spectrometer. The injected gas passes through the pinholes and has a molecular flow, and is ionized by an electron beam in the ion source and moved to the magnet sector.

Table 1. Analytical conditions of precision gas mass spectrometry

Instrument	MAT271
Channel	Faraday cup II
Resolution	220
Resistance	$1 \times 10^{10} \Omega$
High Voltage	6 kV
Emission Current	60 $\mu$ A
Gas Chamber Temperature	$(60.0 \pm 0.1) ^\circ\text{C}$
Internal Pressure	$1 \times 10^{-5}$ Pa

was set so that it does not to exceed 10 Pa to allow all of the gas molecules to move in the molecular flow. The interior temperature of the chamber was maintained at  $(60.0 \pm 0.1) ^\circ\text{C}$  to reduce molecular adsorption and stabilize the speed of molecules. Prior to the measurements, several slits were carefully adjusted to increase the sensitivity of the device to molecules with masses below 6 amu and achieve the accurate measurement of hydrogen isotopes with a low level of uncertainty. Collisions between the ion beam and non-ionized particles were prevented by attaching a turbo molecular pump connected to a rough pump to the flight tube to maintain the gas interior pressure at or below  $1 \times 10^{-5}$  Pa. The gas ions were detected via a Faraday II cup connected to a  $10^{10} \Omega$  resistor, which does not show saturation even at molar fractions approaching the maximum limit of detection (10 V). The flatness of the peaks obtained was less than 0.05 %, indicating a low level of uncertainty.

### 2.3. Resolution of the high-precision mass spectrometer

The presence of  $\text{D}_2$  and  $^4\text{He}$ , both of which have masses of 4 amu, should be considered when analyzing  $\text{D}_2$  using Gas/MS. For a mass spectrometer to separate two peaks of very close atomic mass, the detector resolution should be higher than the resolution at that mass. The resolution may be calculated by the difference between two molecules at the detected mass. The value obtained by dividing the difference between the molecular masses of  $\text{D}_2$  (4.028 amu) and He gas (4.0026 amu) by the respective mass is 158 ( $= 4/(4.028-4.0026)$ ). The resolution of the Faraday

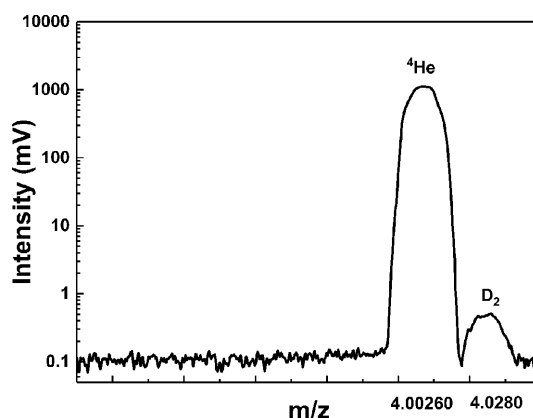

Fig. 3. Peak separation of  $^4\text{He}$  and  $\text{D}_2$  in Gas/MS.

II cup, the detector of the mass spectrometer used in this study, is 220. Hence, the separation between  $\text{D}_2$  and He is adequate. Fig. 3 shows the peak separation determined by injecting a mixture of  $\text{D}_2$  and He gases; the results verified the excellent separation between  $\text{D}_2$  and He by the Gas/MS instrument.

### 2.4. Reference material for hydrogen isotopes

The most important step when analyzing hydrogen isotopes using a high-precision mass spectrometer is determining the instrument sensitivity. The sensitivity of Gas/MS for a given sample can be estimated from the sample pressure and signal intensity measured using either a pure gas or a reference gas containing a known amount fraction of the target. Because the injected sample is transformed into a molecular flow, the measured signals depend solely on the amount fraction of the target gas and not the type or pressure of the gas in the mixture.<sup>16</sup> Hence, the amount fraction of the sample can be determined from the sensitivity of the instrument. In this study, the sensitivity of the Gas/MS instrument for HD gas was estimated using pure HD gas, and the amount fraction of HD present as an impurity in high-purity  $\text{D}_2$  was determined on the basis of this sensitivity.

A total of six measurements, with two repeat measurements for different pressures (0.03, 0.06, and 0.09 mbar), were made upon the injection of pure HD gas to verify the linearity of the signal intensity and pressure. As shown in Fig. 4, the  $R^2$  of the

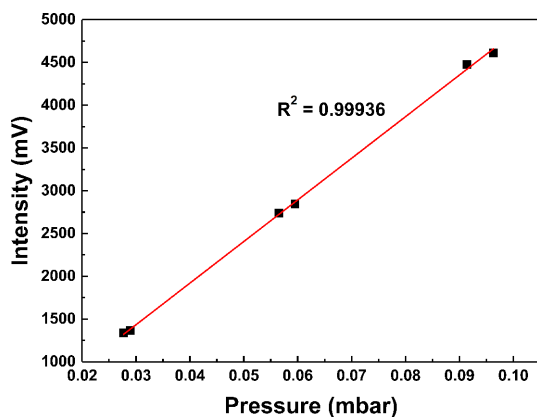

Fig. 4. The Linearity of measured pure HD in Gas/MS.

relationship between the signal intensity and pressure was 0.999361, which indicates their high linearity. The sensitivity of the Gas/MS instrument for HD was determined from the mean of these six repeat measurements.

### 3. Results and Discussion

#### 3.1. HD sensitivity determination and uncertainty test

Pure HD gas (>97 %) was used to determine the sensitivity of the high-precision mass spectrometer, as shown in Eq. (1). The sensitivity obtained can then be used to quantify the isotope impurity HD in RM<sub>A</sub> and RM<sub>B</sub>.

$$S_{HD,i} = \frac{\sum_{j=1}^n (I_{i,j})/n}{P_i \cdot x_{HD}} \quad (1)$$

where  $S_{HD,i}$  is the sensitivity for HD in the  $i^{th}$  measurement;  $x_{HD}$  is the amount fraction of pure gas HD;  $P_i$  is the pressure at the highest  $i^{th}$  measurement;  $I_{i,j}$  is the peak height in the  $i^{th}$  measurement; and  $j$  is the number of peak height measurements used to determine  $I$ , which was  $n = 3$  in this study. The sensitivity of the instrument for HD was determined as the mean of six repeat measurements, as shown in Eq. (2).

$$S_{HD} = \frac{\sum_{i=1}^m (S_{HD,i})}{m} \quad (2)$$

where  $m$  is the total number of repeat measurements.

The uncertainty of the instrument sensitivity, which includes reproducibility and repeatability uncertainties, was calculated using Eq. (3).

$$u^2(S_{HD}) = u_{rep}^2 + u_{repro}^2 \quad (3)$$

The uncertainty of measurement repeatability was assessed as in Eq. (4) using the uncertainty propagation formula, and the uncertainty of reproducibility was calculated as in Eq. (5) assuming a normal distribution.

$$u_{rep}^2 = \frac{u^2(I)}{I^2} + \frac{u^2(P)}{P^2} + \frac{u^2(x_{HD})}{x_{HD}^2} \quad (4)$$

$$u_{repro}^2 = \frac{s^2}{\sqrt{n}} \quad (5)$$

where  $s$  is the standard deviation of the repeat measurements of sensitivity and  $n$  is the number of measurements, which was 6 in this study. All sensitivity calculations are shown in Fig. 5. Each of the six dots indicates the sensitivity determined using Eq. (1), and the uncertainty refers to the standard uncertainty that takes into account the repeatability uncertainty only. The straight line at the center of the plot reflects the final sensitivity for HD determined using Eq. (2), and the red range indicates the expanded uncertainty, which is obtained by multiplying the uncertainty determined using Eq. (3) with the coverage factor ( $k$

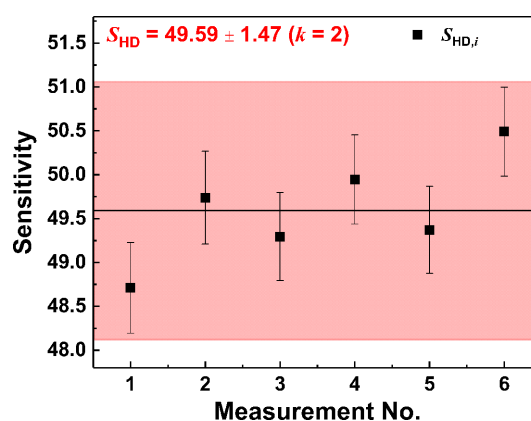

Fig. 5. Measurement of sensitivity for pure HD with uncertainty. The horizontal line in the middle is the averaged sensitivity of each measurement and the red area represents the expanded uncertainty ( $k = 2$ ).

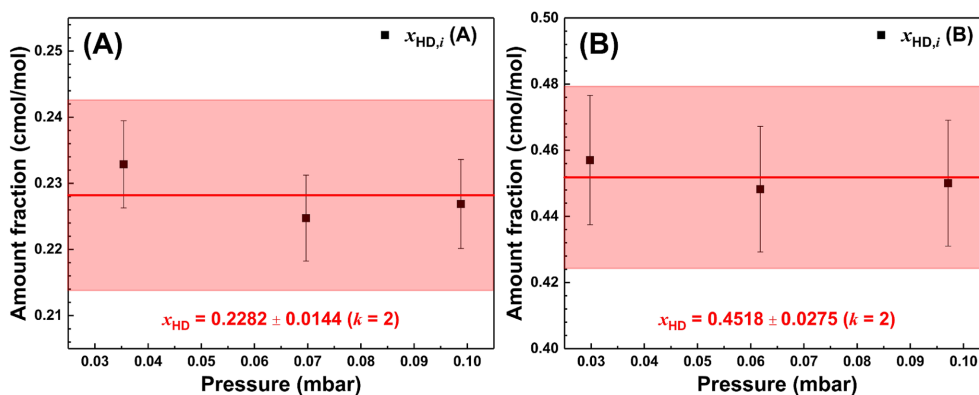

Fig. 6. Amount fraction of HD in  $RM_A$  and  $RM_B$ . The horizontal lines in the middle are the averaged amount fractions of HD in each RM and the red areas represent those expanded uncertainties ( $k = 2$ ).

Table 2. The amount fractions of developed 2 bottles of RM

	Component	Analytical amount fraction/ $\mu\text{mol mol}^{-1}$	Analytical method	Distribution	Applied amount fraction/ $\mu\text{mol mol}^{-1}$	Standard uncertainty / $\mu\text{mol mol}^{-1}$
$RM_A$	$H_2$	<5	Gas/MS	Rectangular	3	1
	HD	2282	Gas/MS	Normal	2282	72
	$D_2$		Gas/MS		997715	72
$RM_B$	$H_2$	<5	Gas/MS	Rectangular	3	1
	HD	4518	Gas/MS	Normal	4518	138
	$D_2$		Gas/MS		995479	138

= 2). The sensitivity of the instrument for HD was  $(49.59 \pm 1.47)$  V/mbar, and all sensitivity calculations were within the level of uncertainty determined.

### 3.2. RM certification and uncertainty test

The molar fraction of HD in  $D_2$  for  $RM_A$  and  $RM_B$  certification is calculated as in Eq. (6) using the sensitivity determined from Eq. (2).

$$x_{HD} = \frac{I}{P \cdot S_{HD}} \quad (6)$$

where  $x_{HD}$  is the amount fraction of HD in  $D_2$ .

$$u^2(x_{HD}) = u_{rep}^2 + u_{repro}^2 \quad (7)$$

Fig. 6 presents the amount fractions of HD in  $RM_A$  and  $RM_B$  obtained using the  $S_{HD}$  calculated from Eq. (2) at different sample pressure. The three points in Figs. 6(A) and 6(B) indicate the amount fractions determined at different sample pressures, and the uncertainty refers to the standard uncertainty that takes into account the repeatability uncertainty

only. The straight line at the center of the plots is the final amount fraction of HD determined using Eq. (6), and the red ranges indicate the expanded uncertainty obtained by multiplying the uncertainty determined using Eq. (7) with the coverage factor ( $k = 2$ ). Hence, the amount fractions of HD in  $RM_A$  and  $RM_B$  are  $(2282 \pm 144)$   $\mu\text{mol/mol}$  and  $(4518 \pm 275)$   $\mu\text{mol/mol}$ , respectively; all amount fraction calculations were within the level of uncertainty determined.

Table 2 presents the amount fraction of  $D_2$  obtained by subtracting the sum of the amount fractions of HD and  $H_2$  from the total amount fractions of all isotopes. The amount fraction of  $H_2$  was below the limit of detection of the instrument, and the uncertainty was determined according to a rectangular distribution.

## 4. Conclusions

In this study, an analytical method was developed to quantify the hydrogen isotope impurities in  $D_2$ . This

novel method applied the sensitivity of pure HD gas determined using a high-precision mass spectrometer with outstanding linearity. The sample was injected into the instrument, and the amount fraction of HD was quantified on the basis of variations in signal intensity and sensitivity at different pressures. Using this novel method, manufacturers of D<sub>2</sub> in South Korea can quantify the amount fraction of HD in D<sub>2</sub> and develop a suitable RM. The amount fractions of HD determined in RM<sub>A</sub> and RM<sub>B</sub> were (2282 ± 144) μmol/mol and (4518 ± 275) μmol/mol, respectively.

For a manufacturer challenged with the lack of a high-precision mass spectrometer and consistent HD gas supply, the RM of hydrogen isotopes must be established to enable impurity analysis for D<sub>2</sub> production. Thus, a quantification method using the sensitivity of the instrument for pure HD gas is essential. In the present work, an RM of hydrogen isotopes was developed to provide D<sub>2</sub> analytical criteria for use across diverse fields. These RMs can enhance the quality of D<sub>2</sub> used in the electronics industry because manufacturers can identify the amount fraction of HD in the gas by using a quadrupole mass spectrometer together with RMs which have two different amount fraction. The RMs may also be valuable in the development of a certified reference material (CRM)<sup>17</sup> using valid procedures.

### Acknowledgements

This research was supported by Research on Measurement Standards for Redefinition of SI Units funded by Korea Research Institute of Standards and Science (KRISS-2022-GP2022-0001).

### References

1. K. B. Wiberg, *Chemical Reviews*, **55**(4), 713-743 (1955).
2. Z. Chen, K. Hess, J. Lee, J. W. Lyding, E. Rosenbaum, I. Kizilyalli, S. Chetlur, and R. Huang, *IEEE Electron Device Letters*, **21**(1), 24-26 (2000).
3. Y. Mitani, H. Satake, H. Itoh and A. Toriumi, *IEEE Transactions on Electron Devices*, **49**(7), 1192-1197 (2002).
4. H. Tsuji, C. Mitsui and E. Nakamura, *Chemical*

- Communications*, **50**(94), 14870-14872(2014).
5. A. Danos, R. W. MacQueen, Y. Y. Cheng, M. Dvořák, T. A. Darwish, D. R. McCamey and T. W. Schmidt, *Journal of Physical Chemistry Letters*, **6**(15), 3061-3066(2015).
6. P. Krumbiegel, *Isotopes in Environmental and Health Studies*, **47**(1), 1-17(2011).
7. C.-H. Park, S.-B. Jo and D.-H. Choe, *Information Display*, **21**(6), 19-27 (2020).
8. Z. Junbo, W. Kuisheng, S. Huitang and W. Shaobo, *International Journal of Hydrogen Energy*, **29**(13), 1393-1396 (2004).
9. B. Topley and H. Eyring, *Journal of Chemical Physics*, **2**(5), 217-230 (1934).
10. P. Roper, V. Barwick, S. Burke, R. Walker and R. Lawn, 'Applications of reference materials in analytical chemistry', Royal Society of Chemistry, 2001.
11. International Organization for Standardization, 'ISO 6142-1:2015 Gas analysis — Preparation of calibration gas mixtures — Part 1: Gravimetric method for Class I mixtures', (2015).
12. S. H. Lee, K. R. Kim, H. S. Kang, D. H. Ahn, S. W. Paek, J. H. Yoo and H. Chung, *Applied Chemistry*, **3**(2), 160-163 (1999).
13. P. Steur, J. S. Kim, D. Giraudi and F. Pavese, *Journal of Chemical Thermodynamics*, **60**, 87-93 (2013).
14. S. Valkiers, M. Varlam, M. Berglund, P. Taylor, R. Gonfiantini and P. De Bièvre, *International Journal of Mass Spectrometry*, **269**(1-2), 71-77 (2008).
15. M. Varlam, S. Valkiers, M. Berglund, P. Taylor, R. Gonfiantini and P. De Bièvre, *International Journal of Mass Spectrometry*, **269**(1-2), 78-84 (2008).
16. P. D. Zeman, *Journal of Applied Physics*, **23**(8), 924-927 (1952).
17. H. Emons, A. Fajgelj, A. M. van der Veen and R. Watters, *Accreditation and Quality Assurance*, **10**(10), 576-578 (2006).

### Authors' Positions

Jinwoo Chang	: Graduate Student
Jin Bok Lee	: Engineer
Jin Seog Kim	: Principal Research Scientist
Jin-Hong Lee	: Professor
Kiryong Hong	: Principal Research Scientist