

Quality-based VoIP charging mechanism design from listening and identification test*

Yunchan Jung**

J. William Atwood***

Jong-Ho Nam****

**School of Information, Communications & Electronic Engineering, Catholic University of Korea

***Department of Computer Science and Software Engineering, Concordia University, USA.

****Department of Psychology, Catholic University of Korea

Providing quality-of service (QoS) guarantees in VoIP applications becomes more challenging in wireless and mobile networks. Then, one of the important issues is to find a mechanism that can probe to what degree the users are satisfied with their experiences and give them service quality guarantees with varying prices depending on the network performance they may experience. In the traditional telephone services, the issue of the quality-based accounting has been relegated to the margins of quality communications. Also existing studies to date rarely deal with quality-based VoIP accounting because it is very difficult to find a suitable VoIP accounting metric. In this paper, we use a methodology of listening and identifying word by word and derive a VoIP accounting metric. Using the accounting metric, we design a quality-based VoIP charging mechanism with a “no charging” window.

Key words : VoIP, Quality of Service, Listening and Identification Test, Quality-based Charging Mechanism, No Charging Window, Psychophysics

* This work was supported by the Korea Research Foundation Grant funded by the Korean Government (MOEHRD) (KRF-2005-042-D00215).

† 교신저자 : Jong-Ho Nam

E-mail: texton@catholic.ac.kr

The Voice over Internet Protocol (VoIP) is one of fastest growing technologies in the world at the moment (Simon, 2006; Ramjee, Kurose, Towsley, & Schulzrinne, 1994). VoIP applications send uniformly spaced voice packets through IP networks, and suffer from packet loss and packet delay variation (jitter). For now, there is no universal solution to satisfy customers who are accustomed to dedicated circuit service. However, from the 4th generation (4G) and all IP (Internet Protocol) devices point of view, the wholesale move from circuit switched telephone calls to VoIP calls will occur in a decade (Simon, 2006). Differently from this positive trend, providing quality-of service (QoS) guarantees becomes more challenging in wireless and mobile networks (Simon, 2006; Moon & Aghvami, 2004). Wireless and mobile networks typically suffer much more loss due to the sources of disruption that come from layered structures (Petcher; Saliba, Beresford, Ivanovich, & Fitzpatrick, 2005). In this circumstance, 'quality-based accounting' is one of important issues from aspects of both services providers and users (Takahashi, Yoshino, & Kitawaki, 2004).

In the 4G and all IP age, a clear point is that different VoIP devices provide different QoS (Quality of Service) levels for similar network impairments. Then, when it comes to dealing with various quality levels, there must be a clear distinction between what happens when the negotiated QoS is achieved and what happens

when it is not achieved. Defining this boundary is quite difficult. One of issues for the complete replacement from telephone calls to VoIP services is to find a mechanism that can probe to what degree the users are satisfied with their experiences up to now and give them service quality guarantees with varying prices depending on the network performance they may experience. The solution for this issue depends on finding an suitable accounting metric. Current VoIP calls, using programs such as Skype and Windows Messenger, are usually free of charge, and only provide best effort services. They lack the ability to ensure that the user receives a suitable quality of service during a call. We argue that VoIP calls can be accepted as a replacement for telephone calls if the charging is done only when the QoS is above a certain level. Thus, we suggest a model of "Simon, 2006 "charging" regions and "non-charging" regions, which alternate as the call proceeds.

The most widely used metric to conduct a quality estimation is the mean opinion score (MOS), that is, the basic approach to assessing quality (Rix, Beerends, Kim, Kroon, & Ghiza, 2006; Egi, Aoki, & Rakahashi, 2007). However, we assume that the intelligibility is a key factor to be used as a VoIP accounting metric that can provide a quantitative distinction between guaranteeing and non guaranteeing services. In this paper, we use a methodology of listening

and identifying word by word and derive a VoIP accounting metric. Our own method is similar to methods using phonetically balanced word list (PB), which are in a category of intelligibility testing methods (Metz, 1999). In our Listening and Identifying Test (LIT), participants are asked to record the word that they hear when the degraded signal is presented to them. For conducting the LIT auditory test, we built a SIP (session initiation protocol) compliant testbed. The recorded results by all participants are evaluated as "success" or "fail" depending on whether the word was recognized correctly or not. Then, we can derive the accounting metric from the relationship between the packet loss level and average LIT success rate.

Studies to date rarely deal with quality-based VoIP accounting mechanisms (Metz, 1999; Ghys & Vaaraniemi, 2003). The final focus of this paper is to propose a charging mechanism that uses the VoIP charging metric to decide whether the current packet belongs to the charging region or to the non-charging region. Our quality-based VoIP charging mechanism is based on a "no charging" window. The no charging window corresponds to the period when the QoS is below the threshold. Improved performance in the quality-based VoIP charging mechanism can be a key differentiator for a certain VoIP service provider when competing against similar providers. Then, it is very important to find a

VoIP accounting metric that can distinguish between meeting the QoS goal and not meeting this goal. The use of the well defined VoIP accounting metric is the first key to making the quality-based VoIP charging mechanism satisfactory to users. The second key is to design the window mechanism that is able to identify the non-charging regions when they occur during a call.

ACCOUNTING METRIC

In order to implement an accounting function for quality-based billing, the accounting metric for VoIP services has to provide the capability to decide whether the delivered VoIP quality meets an acceptable level on a real time basis or not. The accounting metric needs to be derived from the network and device quality parameters shown in Fig. 1.

Existing approaches to assessing quality can be considered as a candidate for the solution to find the VoIP accounting metric. The basic approach to assessing quality is done through the subjective perception of human listeners (Rix et al., 2006; Egi et al., 2007). The most widely used metric to conduct a subjective test is the MOS. In the MOS, to determine listening quality, users are asked to rate 'the quality of the speech', for a 5- to 8-second sample, on a five-point scale: excellent (5), good (4), fair (3), poor (2), and bad (1). The arithmetic mean of

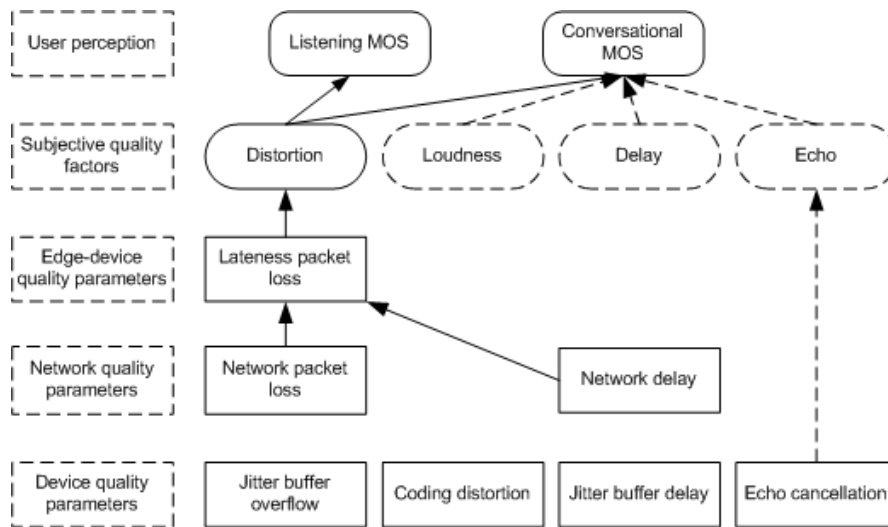

Fig. 1. Parameters that determine the VoIP quality

all listeners' scores collected is a MOS. While subjective tests are the ideal way to make decisions for system design such as the selection of a codec for an international standard, they are unsuitable for real-time applications such as immediate quality measuring for VoIP services. Next, the objective approach has more recently been applied to real-time assessment of VoIP systems by measuring the intermediate quality parameters (Simon, 2006). As shown in Fig. 1, they consist of network quality parameters and device quality parameters. Here, device quality

parameters are static because they are determined before a call initiation. That is, device quality parameters are never changed during a call. On the other hand, network quality parameters change dynamically depending on the network impairments condition. Here, the edge-device quality parameter means the lateness packet discarding within jitter buffers at the edge-device. Fig. 2 shows the simple 4G device architecture from the viewpoint of impact on voice quality. Recall that user perception on voice quality is affected by multiple subjective

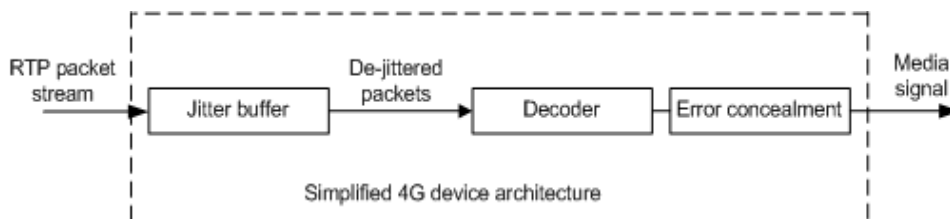

Fig. 2. Simple 4G device architecture

quality parameters: distortion, loudness, delay, and echo. Here, subjective quality factors depend on network quality parameters and device quality parameters. However, for 4G devices, the all network quality parameters are converged into the edge-device quality parameter: lateness packet loss. It is because when packets pass over jitter buffer, network delay issue is mapped into packet loss issue by interpreting all delays exceeding a given playout delay as packet losses. Then, the lateness packet loss comes to a dominant parameter which affect the dominant subjective quality factor: distortion. In order to do VoIP quality-based accounting for 4G services, lateness packet loss needs to be measured on a real time basis. Fortunately, the RTP (Real Time Protocol) header contains a packet sequence number field. One can meter packet loss status easily by monitoring the value of this field.

The next issue is to find the packet loss boundary, which differentiate “charging” regions and “non-charging” regions. We assume that the intelligibility test is advantageous to investigate a VoIP accounting metric that can provide a quantitative distinction between charging and non-charging regions. Since the standard tests involve a substantial effort to implement, we created a simple method to evaluate the merit of our idea. This method is similar to methods using phonetically balanced word lists (Steele & Cassel, 1963). Since the assessed sample for a

word-based test is very short (typically less than one second), it is possible to formulate a test methodology that takes significantly less time to complete. In our word-by-word identification test, participants are asked to do a directed action: from a sample list that consists of several types of words, record the word that they hear when the degraded signal is presented to them. The recorded results by all participants are evaluated as ‘success’ or ‘fail’ depending on whether the word was recognized correctly or not. Then, the success rate is calculated as an average of total ‘success’s divided by total ‘success’s + ‘fail’s]. The goal of our word-based intelligibility test is to show that the packet loss rate can be applied for a simple VoIP accounting metric.

VOIP TESTBED

Metering the Internet An accurate understanding of current network statistics, such as average loss or jitter is needed to model practical network impairments. As an example of current network impairments, we measured network loss and jitter on an IP network between Korea and Sweden. Differently from two categories of internet measurements: passive and active measurements (Claffy, 2000; Network Time Protocol, v. 3), our experiment does not need to maintain precise time synchronization between the MH and the SH because two hosts

use their own precise clocks and time difference between them does not cause bad effects when measuring jitter and network loss. At the measurement phase, the real-time streaming protocol (RTSP) compliant audio software we developed begins to run at each side. The sending host (SH) sends a VoIP packet stream of the original sample of which packet inter-departure time is 20 ms and size of a voice payload is 160 bytes. Also, VoIP packets from the SH contain departure timestamps (DTs) and sequence numbers (SEQs). The timestamp values correspond to their departure time from the SH. When a packet arrives at the measurement host (MH), its network delay is computed by subtracting both its timestamp value from the arrival time and the time difference value between the SH and MH. By

examining the sequence number of an arriving packet, the MH monitors whether there is a lost packet or not. The hosts chosen were cnrl.cuk.ac.kr at The Catholic University of Korea serving as SH and tekpc4216.tek.bth.se at Blekinge Institute of Technology in Sweden as MH.

The original sample contains 90 different words, which are recorded by a man in a quiet place during around 3 minutes. Therefore for the LIT, each word corresponds to the unit of the quality assessment. Then, the sample is encoded into 1,400 K Bytes PCM file, which corresponds to a series of 8,750 VoIP packets. Starting at 10:00 AM, July 10, 2008, the SH sent 8 750 packets every 10 minutes. We repeated the 8 750 measurement 50 times for the same sample. As a result, we obtained

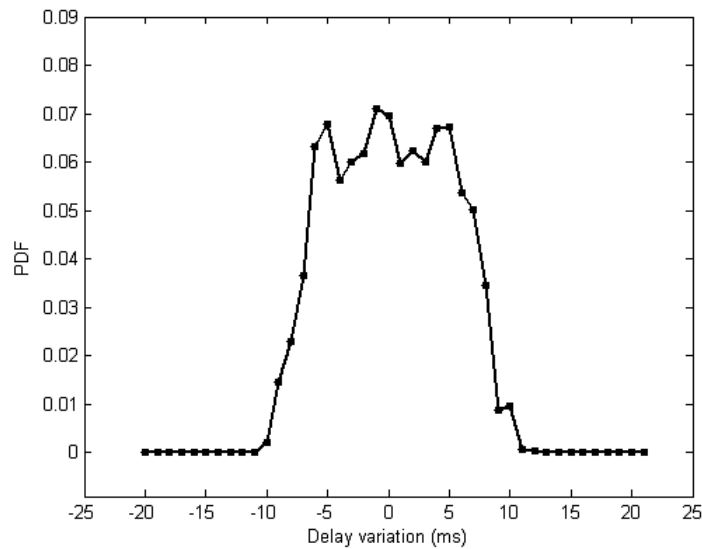

Fig. 3. PDF of measured network delay

around 8 750*50 packet delay variations (i.e., jitter) as the sequence of packet delay differences from the mean.

Fig. 3 shows the probability density function for the delay variations. Note that the range of variation is from -20 to 21 ms. By virtue of observation for the path from Korea to Sweden, we found average jitter level (Jit) to be 4. So, we assumed the case of $Jit = 8$, which is double the amount of current jitter. This means that we considered the worst case scenario relevant to the jitter level. Fig. 4 plots the packet loss rates for 50 experiments. It is seen that packet loss percentage ranges from 0 to around 0.4. Note that the current Internet performs better than our expectation from the viewpoint of network loss.

Building the testbed Packet network degradations can be caused by two broad categories: packet loss and packet delay variation. We need to state that our charging metric on providing accounting is simply based on packet loss within network and lateness loss at the edge-device. This is because as we see in Fig. 3 actual jitter levels are small enough to be neglected in the network impairment scenario. Also, even though the current Internet performs better than our expectation from the viewpoint of network loss, the experiments have been done for packet loss rates up to 80% in order to obtain a clear view of the interaction between average word recognition percentages and packet loss rates.

As shown in Fig. 5, to allow us to conduct the LIT auditory test, we built a SIP-compliant

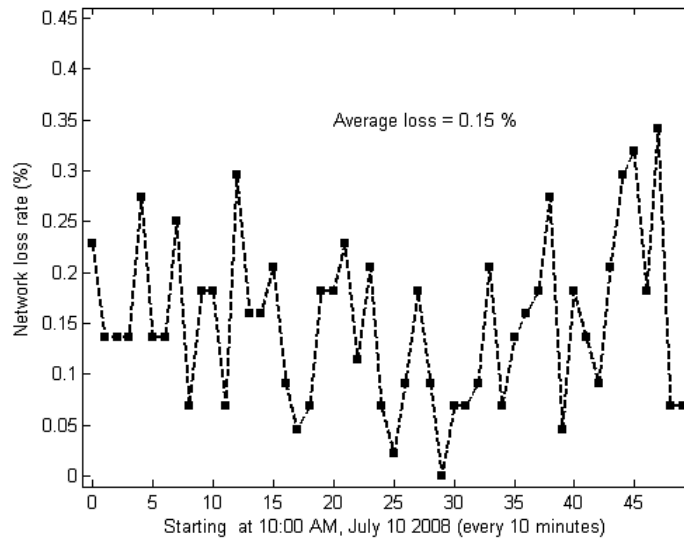

Fig. 4. Packet loss rates for successive 50 experiments

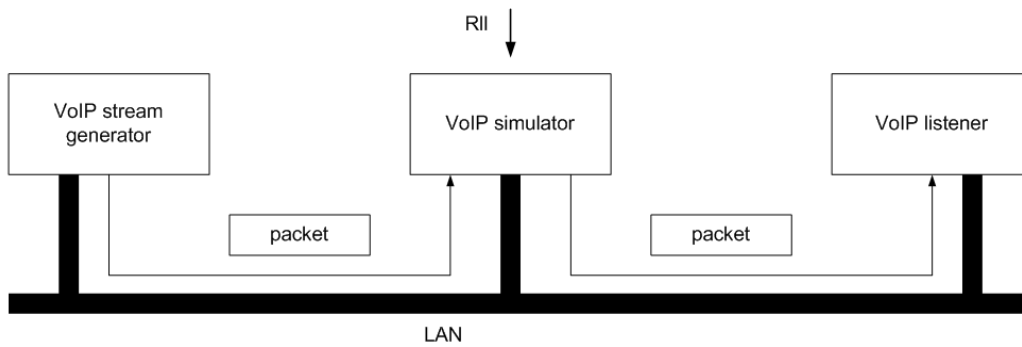

Fig. 5. VoIP testbed

testbed, which consists of a VoIP stream generator, a VoIP simulator and a VoIP listener. Also, we embedded a Loss Generator Model (LGM) in the VoIP simulator. The LGM uses loss parameter when converting the original regular packet stream of the test sample from the VoIP stream generator into the test packet stream of a distorted sample modified.

The VoIP stream generator sends VoIP packets, which are transmitted at even intervals with any packetization scenario. However, we simulated the transmission of G.711 speech data grouped into 20 ms frames, one frame per packet. The VoIP simulator converts these packets with loss of 0 percent into those with arbitrary packet losses. Then, a parameter of network loss rate (R_{ll}) can be chosen to correspond to any network impairment scenario, where R_{ll} can be one of 9 different packet loss levels. The parameter of R_{ll} for a given test sample is used to make each packet in this test

sample suffer from artificial network impairment with random amounts of packet loss. Each packet would be dropped with the rate of R_{ll} . When the simulator receives a packet from the generator, the LGM in the simulator determines whether the received packet has to be dropped or sent to the listener. We adopted a 'fully-random model', where each packet is to be removed with probability, R_{ll} . That is, when a packet arrives at the simulator, it generates a random number with range between 0 and 1. If the selected random number falls into the range from 0 to R_{ll} , the packet should be dropped.

Method

When using listening tests for assessing perceptual quality, the unit for listening is relatively large in order to evaluate the overall quality over a whole sample period. Also, users are asked to identify 'the overall quality of the speech' on a five-point scale. A typical duration

of a phone call is order of 2 min, and several studies have done to find how timescales may affect quality perception. For example, Gray reported the primary effect that the first part of the speech sample had greatest weight on overall MOS (Jung & Atwood, 2005). The LIT can assess the quality of the speech with precision for the following two reasons. In the LIT, the unit for listening and identification can be as small as possible by assessing not the overall quality but the short-term quality based on one word length. That is, each word corresponds to the unit of identification. The other reason is that in the LIT, each subject listens to a series of words in the sample list and writes down each word heard on a word by word basis through the whole session of a sample list. This can produce more accurate results rather than a five-point scale in the MOS. In the LIT, each subject listens to the VoIP Listener and carries out the identification task based on a psychological experiment where the metric of LIT success rate is used as the quality-based accounting metric in the VoIP charging mechanism we propose.

Participants One of the authors and 3 native-korean observers participated in the experiment. All had normal hearing ability.

Materials The G.711 speech codec was used. The payload size of the voice packet was 160

bytes in G.711. An artificial network impairment condition could be one of 9 different packet loss levels: 2, 10, 20, 30, 40, 50, 60, 70, and 80 in percentage. In the LIT, we used 3 types of words: 30 words with one syllable, 30 words with two syllables, and 30 words with three syllables. The materials consisted of 90 Korean words recorded by female or male voice. Each word list consisted of 30 one-syllable words (e.g., son, cup, pot, etc.), 30 two-syllable words (e.g., saram, sorry, etc.), and 30 three-syllable words (e.g., hurry-up, hal-mu-nee, etc.). The 90 words in a list were randomly ordered and sent to the VoIP simulator in sequence. They were degraded using a given network impairment condition. Subjects listened and identified word by word. Each word suffered from a given artificial network packet loss when it traveled through the VoIP Simulator.

Procedure The intelligibility test was performed in laboratory facilities with high-quality headphones. Each participant heard a series of 90 words in the sample list from the VoIP Listener. And he (or she) was asked to record each word he (or she) heard. The silence interval between two adjacent words does not exceed 1.0 second. The recorded results by the participants were evaluated as 'success' or 'fail' whether they recognized each word correctly or not. Then, the LIT success rate is calculated as an average of total 'success's divided by total

['success's + 'fail's].

Results

It should be noted that all the quality performances plotted on Fig. 6 shows their results while the jitter buffer in the VoIP listener is operating in the way of the fixed playout algorithm for every experiment. The VoIP listener plays packets at their playout schedules of each beginning at the fixed value of 150 ms after their departure times from the VoIP stream generator. This means that the jitter buffer at the VoIP listener removes jitter completely because each packet's end-to-end delay does not exceed around 50 ms.

Fig. 6 shows the average LIT success rates for different packet loss levels ($R//$). Each data point

corresponds to $(48 * 30)$ sample observations. It can clearly be seen that for the packet loss of 10%, the LIT performance for words with 1 syllable decreases to 90% while the performances for words with 2 syllables and 3 syllables remain at 100%. For the packet loss range from 20% to 50%, we can see that words with more syllables show better quality in the LIT success performance. However, for the range where $R// > 50%$, words with fewer syllables show better quality in the LIT performance. The quality in the LIT performance can differ by more than 10% for words with different numbers of syllables. Three graphs in Fig. 6 clearly show the packet loss of 50% is the turning point between having advantage and disadvantage when we hear words with multiple syllables. Even though the measured packet loss in the

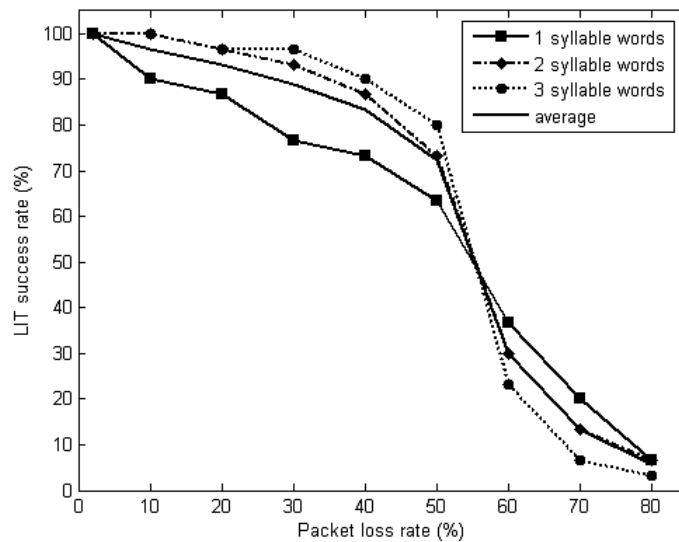

Fig. 6. LIT success rates for 3 types of words

Internet was less than 1%, we ‘stress-tested’ for packet losses of up to 80%, until the LIT performance was driven down to below 10%, to demonstrate the robustness of the proposed measures. However, for the present Internet, we need to pay attention to the packet loss range below 10%. It could be concluded that up to an average 10% packet loss, listening ability in recognizing a word correctly can be perfect unless we use words with 1 syllable.

The LIT performances plotted in black line show average results for 3 types of words as a function of packet loss. Therefore, each data point corresponds to (48 * 90) sample observations. As *Rll* increases to 40%, the LIT success performance begins to decrease very rapidly. Assuming that under the severe

condition such as the tactical situation in the military network, we need at least the LIT success rate of 80% in order that a sentence consisting of several words may be understood, up to 40% network loss can be acceptable. According to Simon (2006), with an average 40% packet loss, the MOS quality is usually only 1.0 (on a five-point scale). Thus, the basic MOS metric is not suitable for using quality-based accounting metric.

In Fig. 6, words with one syllable show about 90% success percentage when loss rate=10%, on the other hand, words with 3 syllables show above 98% performance for the same loss condition. It is reasonable to assume that a sentence with multiple words will show better sentence-based recognition performance

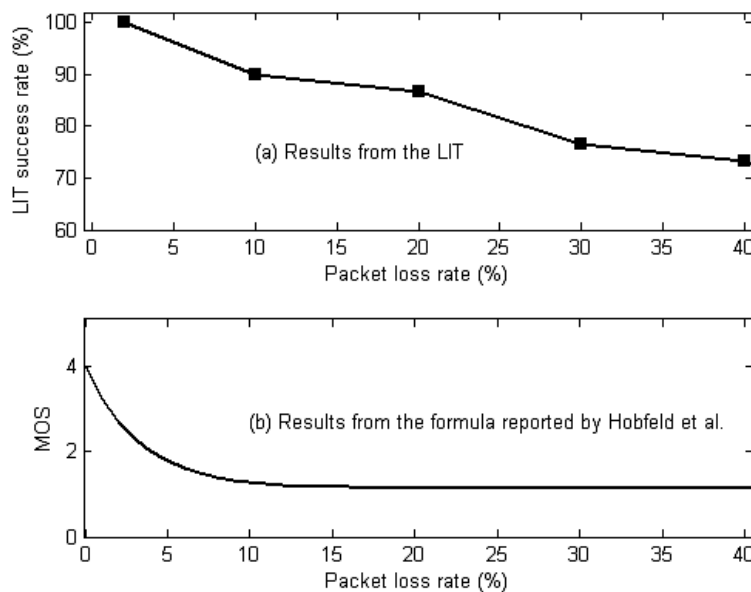

Fig. 7. Comparisons of (a) LIT success rate with (b) estimated MOS value

than words with multiple syllables. We can also see from the data that a word with fewer syllables would impair human conversation much more. This is a qualitative example of the reason why we say ‘b as in boy’ instead saying simply ‘b’ in an important telephone call.

Fig. 7 shows the relationship between the average LIT success rates and MOS values. Considering the worst case, we derive the accounting metric from the LIT results using words with one syllable. The plot below in Fig. 7 is from results by using the formula in Hobfeld, Hock, Tran-Gia, Tutschku, & Fiedler (2008).

Conclusions

PROPOSING QUALITY-BASED VOIP CHARGING MECHANISM Now, the most important issue in this paper is to derive the VoIP accounting metric from the LIT results.

We focus on the packet loss condition of 10% in Fig. 7. We suggest that a packet loss of 10% can represent a boundary between charging and not charging for VoIP services, because under the condition of 10% packet loss, sentence recognition performance will show around 90% even under the worst condition of one syllable words. The LIT success rate of 90% in the worst-case scenario corresponds to the boundary to identify whether the users are satisfied with their experiences or not. Relying on this idea, we propose a VoIP charging mechanism.

The charging mechanism works on a loss event. When a packet loss event occurs, the mechanism begins to compute loss percentages. During the unit period of a loss event (where the unit period is equal to the packet interarrival time in the packet stream), the loss percentage set to 100%. Then, for every correct packet arrival, the loss

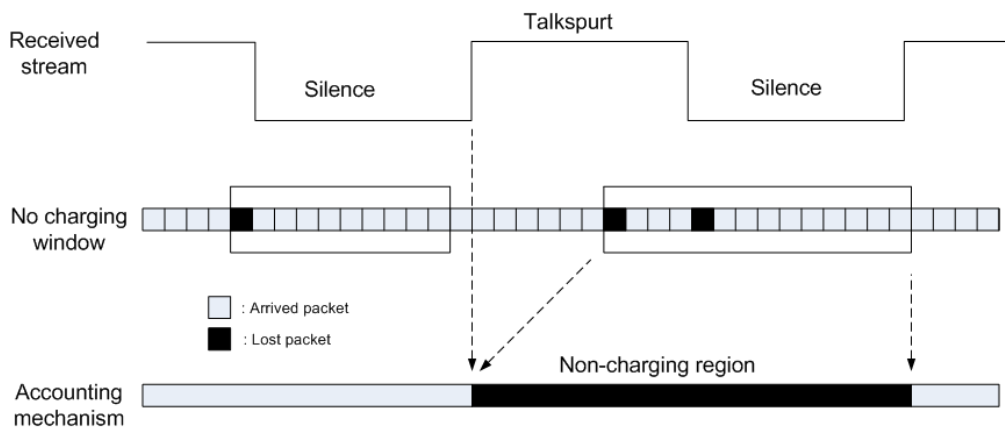

Fig. 8. VoIP charging mechanism

percentage decreases. For example, after 9 correct packets following the loss event, then, the loss percentage decreases to 10%. Then, as shown in Fig. 8, the first window of total 10 periods should not be counted for billing. That is, the window belongs to the 'no charging' region. From the instant when loss rate falls to below 10%, accounting begins to be effective, that is, the 'no charging' window ends. Also whenever a new loss event occurs, the mechanism renews the loss percentage as 100%. If a loss event occurs again during an effective no charging window, the no charging window will be extended until the loss percentage falls to 10%. We point out two important characteristics of our charging mechanism. First of all, this mechanism is designed based on our results from the LIT test. Next, the mechanism works on the loss parameter, that is, loss is the dominant factor for the accounting.

Concluding Remarks The issue of the quality-based accounting has been relegated to the margins of quality communications in the traditional telephone services. Furthermore existing studies to date rarely deal with quality-based VoIP accounting because it is very difficult to find a suitable VoIP accounting metric. In this paper, we used a methodology of listening and identifying word by word and derived a VoIP accounting metric. Using the accounting metric, we designed a quality-based

VoIP charging mechanism with a 'no charging' window. We found that the packet loss condition of 10% represents a useful boundary between charging and not charging for VoIP services because under the condition of 10% packet loss, sentence recognition performance will show around 90% even under the worst condition of one syllable words.

Relying on this result, we proposed a VoIP charging mechanism which has the following principle of no charging window. At the beginning of a loss event, the loss percentage set to 100%. Then, for every correct packet arrival, the loss percentage decreases. The no charging window will be extended until the loss percentage falls to 10%. From the instant when loss rate falls to below 10%, the charging window begins. Also whenever a new loss event occurs, the mechanism renews the loss percentage as 100%.

we argue that a step toward complete replacement of telephone calls by VoIP calls will be possible if the quality-based charging mechanism is fully developed.

REFERENCES

- Claffy, K. C. (2000). Measuring the Internet. *IEEE Internet Computing*, 1, (4), 73-75.
- Egi, N., Aoki, H., & Takahashi, A. (2007). Objective quality evaluation method for noise-reduced speech. *MESAJIN*.

- Ghys, F. & Vaaranemi, A. (Jan. 2003). Component-based charging in a nextgeneration multimedia network. *IEEE Communications Magazine*, 41, (1), 99-102.
- Hobfeld, T., Hock, D., Tran-Gia, P., Tutschku, K., & Fiedler, M. (May 2008). Testing the IQX hypothesis for exponential interdependency between QoS and QoE of voice codecs iLBC and G.711. *in Proc. 18th ITC Specialist Seminar on Quality of Experience*, Karlskrona, Sweden, 105-114.
- Jung, Y. C. & Atwood, J. W. (2005). QoS-Related accounting architectures for VoIP services. *in Proceedings of The 20th International Technical Conference on Circuits/Systems, Computers and Communications (ITC-CSCC 2005)*, 4, 1475-1476. July 4-7, Jeju: Korea.
- Metz, C. (November 1999). AAA protocols: authentication, authorization, and accounting for the Internet. *IEEE Internet Computing*, 75-79, .
- Moon, B. & Aghvami, A. H. (2004). Quality-of service mechanisms in All-IP wireless access networks. *IEEE J. on Selected Areas in Comm.Proc.-Commun.*, 22, (5), 873-888.
- Network Time Protocol (version 3) (1992). Specification, Implementation and Analysis. Network Working group, RFC 1305.
- Petcher Adam. QoS in Wireless Data Networks. http://www.cs.wustl.edu/jain/cse574-06/ftp/wireless_qos/index.html
- Ramjee, R., Kurose, J., Towsley, D., & Schulzrinne, H. (1994). Adaptive playout mechanisms for packetized audio applications in wide-area networks. *In Proc. IEEE Infocom, 1994*, 680-688.
- Rix, A. W., Beerends, J. G., Kim, D. S., Kroon, P., and Ghiza, O. (2006). Objective assessment of speech and audio quality-technology and applications. *IEEE Trans. Audio, Speech and Language Processing*, 11, (8), 1890-1901.
- Saliba, A. J., Beresford, M. A., Ivanovich, M., & Fitzpatrick, P. (2005). Userperceived quality of service in wireless data networks. *Personal and Ubiquitous Computing*, 9, (5), 413-422.
- Simon, R. B. (2006). VoIP quality assessment: taking account of the edge-device. *IEEE Trans. Audio, Speech and Language Processing*, 11, (14), 1977-1983.
- Steele, R. & Cassel, L. (1963). Effect of transmission errors on the intelligibility of vocoded speech. *IEEE Transactions on Communications Systems*, 11, (1), 118-123.
- Takahashi, A., Yoshino, H., & Kitawaki, N. (July 2004). Perceptual QoS Assessment Technologies for VoIP. *IEEE Communications Magazine*, 28-34.
- 1 차원고접수 : 2010. 9. 1
 2 차원고접수 : 2010. 9. 18
 최종게재결정 : 2010. 9. 25

청취-확인 검사를 이용한 품질 기반 VoIP 설계

정 윤 찬*

J. William Atwood**

남 중 호***

*가톨릭대학교 정보통신전자공학부

**Department of Computer Science and Software Engineering, Concordia University

***가톨릭대학교 심리학과

VoIP 응용에서 서비스의 품질 보장은 무선 네트워크와 이동통신 네트워크 환경에서 날로 어려운 과제가 되고 있다. 그러므로 중요한 주제 중 하나는 사용자가 자신의 경험에 비추어 만족할 수 있는 정도를 엄밀하게 조사할 수 있는 기제를 찾아서, 소비자에게 자신들이 경험하는 네트워크의 수행상태에 따라 연동하는 가격 수준을 지닌 서비스의 질적 보장을 제시하는 것이다. 전통적인 전화 서비스 시스템에서는 품질 기반 요금제는 단편적으로만 통화 품질을 반영해 책정되고 있다. 또한 지금까지는 품질 기반 요금체계를 다루는 연구가 적었는데, 그 이유는 적합한 VoIP 요금체계 분류표를 찾아내기 힘들었기 때문이다. 본 연구에서는 통신 상태에 따른 정보 누수 정도를 정신물리학적으로 조작하여 단어 수준에서의 청취-확인 검사 방법을 사용하였으며, 이를 이용하여 VoIP 요금체계 분류표를 도출하였다. 요금체계 분류표를 사용하여 “무과금 영역창”을 지닌 품질 기반 VoIP 과금 기제를 설계하였다.

주제어 : VoIP, 서비스 품질, 청취-파악 검사, 품질 기반 과금 기제, 무과금 영역창, 정신물리학