

Non-Orthogonal Multiple Access (NOMA) to Enhance Capacity in 5G

Sungmook Lim

Dept. of Electronic Engineering

Korea National University of Transportation, 50 Daehak-ro, Chungju-si, Chungbuk, 380-702 Korea

Kyunbyoung Ko

Dept. of IT Convergence & Dept. of Control and Instrumentation Engineering

Korea National University of Transportation, 50 Daehak-ro, Chungju-si, Chungbuk, 380-702 Korea

ABSTRACT

Non-orthogonal multiple access (NOMA) where all users share the entire time and frequency resource has paid attention as one of the key technologies to enhance the spectral efficiency and the total throughput. Nevertheless, as the number of users and SIC error increase, the inter-user interference and the residual interference due to the SIC error also increase, resulting in performance degradation. In order to mitigate the performance degradation, we propose grouping-based NOMA system. In the proposed scheme, all users are divided into two groups based on the distance between the BS and each user, where one utilizes the first half of the bandwidth and the other utilizes the rest in the orthogonal manner. On the other hand, users in each group share the spectrum in the non-orthogonal manner. Grouping users can reduce both the inter-user interference and residual interference due to the SIC error, so it can outperform conventional NOMA system, especially in case that the number of users and the SIC error increase. Based on that, we also present the hybrid operation of the conventional and the proposed NOMA systems. In numerical results, the total throughput of the proposed NOMA systems is compared with that of the conventional NOMA systems with regard to the number of users and SIC error. It is confirmed that the proposed NOMA system outperforms the conventional NOMA system as the number of users and the SIC error increase.

Key words: Non-orthogonal Multiple Access (NOMA), Power Allocation, Successive Interference Cancellation (SIC), Sum rate.

1. INTRODUCTION

Recently, according to the increasing of smart phones, wireless internet applications and multimedia services, mobile network traffic has been explosively increasing [1]. This trend will be expected to be mobile traffic volume 1000 times larger than today's by 2020 [2]. In this reason, the importance and research of 5G system to drastically enhance the capacity, compared with 4G system including long term evolution – advanced (LTE-A) have paid attention.

In order to cope with the explosive increase in data traffic and enhance the system capacity in 5G, 1000-fold capacity enhancement has become one of the most important issues in the 3rd generation partnership project (3GPP) workshop on release 12 and onwards on June 2012 [3]. In this workshop, various core technologies for higher spectral efficiency under massive small cell environment have been introduced.

In particular, non-orthogonal multiple access (NOMA) scheme has been proposed as one of several promising

technologies that can improve capacity in 5G systems [4]-[9]. In NOMA, all users share limited resources (time and frequency) by using superposition coding. Because the communication resources in NOMA are shared by all the users, the sum capacity can be enhanced, compared with orthogonal multiple access (OMA) such as orthogonal frequency division multiple access (OFDMA). However, inter-user interference due to resource sharing occurs, resulting in performance degradation. For this, a successive interference cancellation (SIC) scheme is required in the receiver.

SIC performance is dependent on the transmission power of each user in downlink (DL) NOMA systems. In [10], the authors proposed the optimal power allocation scheme to maximize edge-user throughput under the condition that total user throughput in NOMA is the same as that in OMA. In [11], the authors proposed a power allocation method based on proportional fairness scheduling and in [12], a suboptimal power allocation method to reduce complexity was proposed.

In these previous works, SIC is assumed to be perfectly performed without SIC error. However, in practical systems, SIC error does occur, resulting in performance degradation [13]. Furthermore, even though SIC is perfectly performed, residual interference exists, which is not removed by SIC because its

* Corresponding author, Email: kbko@ut.ac.kr

Manuscript received Nov. 09, 2015; revised Nov. 16, 2015; accepted Nov. 20, 2015

transmission power is lower than that of the desired signal. Therefore, as the number of the total users increases, total capacity is degraded by the residual interference.

In this paper, a new NOMA scheme based on user grouping is proposed in order to mitigate performance degradation due to the inter-user interference as well as SIC error. In the proposed grouping-based NOMA scheme, all the users do not share all spectrum resource. Instead, all the users are divided into two groups based on the distance between the base station (BS) and each user. Each group utilizes the half of the total frequency resource in the orthogonal method, respectively. On the other hand, users in each group share the half of the total frequency resource in the non-orthogonal method. We analyze the performance of the grouping-based NOMA, which depends on the number of users, the SIC error and the total transmission power. We compare the performance of the grouping-based NOMA with the conventional NOMA and present the condition that the grouping-based NOMA outperforms the conventional NOMA with respect to the number of users, the SIC error and the transmission power. In simulation results, we compare the performance between them according to the number of users, the SIC error and the transmission power.

The remainder of this paper is organized as follows: Section 2 describes the system model of the general NOMA. In Section 3, a new NOMA scheme is proposed and the performance of the proposed scheme is analyzed. The numerical and simulation results are presented in Section 4 and also concluding remarks are given in Section 5.

2. CONVENTIONAL NOMA SYSTEM

The conventional DL NOMA system is depicted in Fig. 1. It consists of one BS and K users. For simplicity, the k-th user ($k \in \{1, 2, \dots, K\}$) assumed to be located at the k-th distant position from the BS. The BS transmits a signal for the k-th user over the total bandwidth which is denoted as W , x_k , with the transmission power, P_k . Then, the transmission signal over W bandwidth, x , can be written as:

$$x = \sum_{k=1}^K \sqrt{P_k} x_k \quad (1)$$

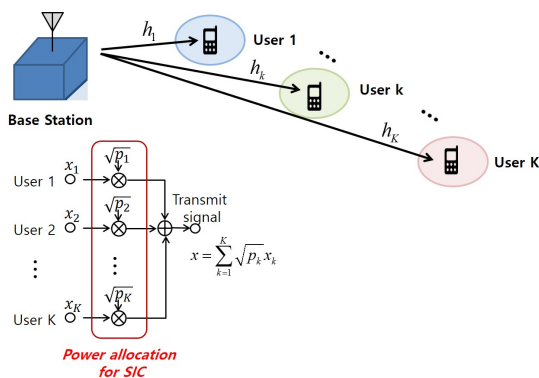

Fig. 1. Conventional DL NOMA System Model

In the receiver of the k-th user, the received signal can be written as:

$$y_k = h_k x_k + n_k = h_k \left(\sum_{k=1}^K \sqrt{P_k} x_k \right) + n_k \quad (2)$$

In (2), the channel, h_k , is denoted as the combination of the frequency domain complex channel coefficient and path loss between the BS and the k-th user and is modeled as complex Gaussian distributed reflecting the path loss due to the distance between the BS and the k-th user. n_k denotes complex additive white Gaussian noise (AWGN) in the receiver of the k-th user where mean and variance are zero and σ_n^2 , respectively. In addition, P_k is the transmission power of the k-th user. In DL NOMA system, the higher power is allocated to the user with the larger channel gain [14]. In other words, if $|h_1|^2 > |h_2|^2 > \dots > |h_K|^2$, the allocated power is as follows:

$P_1 < P_2 < \dots < P_K$. As for the user with larger channel gain (i.e., the distance between the BS and the user is shorter), SIC can be accurately performed, so SIC is performed, with allocating lower power. On the other hand, as for the user with smaller channel gain (i.e., the distance between the BS and the user is longer), the received signal power is also smaller, so it is hard to perform SIC. In this case, the desired signal is directly detected without SIC, with allocating higher power. It is noted that there exists inter-user interference which is not removed by SIC, after performing SIC in the receiver of the k-th user.

Therefore, after receiving the signal, y_k , at the k-th user, all the signals from x_{k+1} to x_K are successively detected and extracted from y_k by SIC. In this case, the received signal to interference plus noise ratio (SINR) of the k-th user can be expressed as

$$SINR_k = \frac{P_k |h_k|^2}{I_e + I_r + \sigma_n^2}, \quad (3)$$

where I_e denotes the inter-user interference from the signals from x_1 to x_{k-1} , which is not removed after SIC and can be expressed as

$$I_e = \sum_{i=1}^{k-1} P_i |h_i|^2 \quad (4)$$

I_r denotes the residual interference occurring due to SIC error and can be expressed as

$$I_r = \sum_{i=k+1}^K P_i |h_i|^2 |x_i - \hat{x}_i|^2, \quad (5)$$

where $\hat{x}_i (i \in \{k+1, \dots, K\})$ is the detected signal for SIC.

From (3)-(5), the rate of the k-th user, R_k , can be easily obtained as

$$R_k = W \log_2 \left(1 + \frac{P_k |h_k|^2}{\sum_{i=1}^{k-1} P_i |h_i|^2 + \sum_{i=k+1}^K P_i |h_i|^2 |x_i - \hat{x}_i|^2 + \sigma_n^2} \right) \quad (6)$$

Also, the sum rate, R , is

$$R = \sum_{k=1}^K R_k. \quad (7)$$

3. THE PROPOSED NOMA SYSTEM

3.1 Grouping-based NOMA Scheme

As shown in (4)-(5), as the number of users and SIC error increase, I_e and I_r drastically increase. Therefore, the SINR and throughput of the k-th user can be. In this case, sharing the entire frequency resource by all the users cannot guarantee the performance enhancement, compared with OMA systems.

To mitigate the performance degradation due to the number of users and the SIC error, we propose a grouping-based NOMA scheme. First, all the users are sorted according to the distance between the BS and each of them as shown in Fig. 1. Then, all users are divided into two groups: in Group 1, the users with the odd index are included and the others are included in Group 2 as follows:

$$s_1 = \left\{ s_i : i=2j-1, 1 \leq j \leq \frac{K}{2} \right\} \quad (8)$$

$$s_2 = \left\{ s_i : i=2j, 1 \leq j \leq \frac{K}{2} \right\} \quad (9)$$

where s_1 and s_2 are denoted as Group 1 and Group 2, respectively. Users in s_1 share the first half of the bandwidth and users in s_2 share the rest. It is noted that s_1 and s_2 exclusively utilizes bandwidth in the orthogonal manner. In the grouping-based NOMA, each user utilizes the half of the entire bandwidth compared with the conventional NOMA, so the throughput could be reduced. However, I_e and I_r can be also reduced, so the total throughput can outperform that of the conventional NOMA as the number of users and the SIC error increase.

3.2 Power Allocation Method

As mentioned above, the optimal and suboptimal power allocation methods have been already proposed [7]-[9] and any of them can be applied in the proposed NOMA system. However, in [7]-[9], the main target is to guarantee fairness,

whereas we focus on enhancing the total throughput compared the conventional NOMA in this paper. Furthermore, the previous power allocation schemes have high complexity. In this reason, we consider a simple power allocation method in this paper.

The transmission power of the k-th user in Group i ($i = 1$ or 2), $P_{i,k}$, is presented as [14]

$$P_{i,k} = \frac{\sqrt{|h_{i,K-k+1}|^2}}{\sum_{k=1}^K |h_k|^2} \quad (10)$$

In (10), the transmission power of the k-th user is inversely proportional the channel gain. That is, in each group, the lowest power is allocated to the user closest to the BS and the highest power is allocated to the user farthest from the BS. In order to use the total transmission power of the proposed NOMA scheme equal to that of the conventional NOMA for fairness, the transmission power of the kth user is normalized by the sum of all the channel gains.

3.3 SINR and Throughput Performance

After users in each group perform SIC, the SINR of the j-th ($1 \leq j \leq \frac{K}{2}$) user in Group i ($i = 1$ or 2) can be written as:

$$\text{SINR}_{i,j} = \frac{P_{i,j} |h_{i,j}|^2}{I_{i,e} + I_{i,r} + \sigma_n^2}, \quad (11)$$

where $I_{i,e}$ and $I_{i,r}$ are the inter-user interference and the residual interference due to the SIC error, respectively, and can be expressed as follows:

$$I_{i,e} = \sum_{l=1}^{j-1} P_{i,l} |h_{i,l}|^2 \quad (12)$$

$$I_{i,r} = \sum_{l=j+1}^{K/2} P_{i,l} |h_{i,l}|^2 |x_{i,l} - \hat{x}_{i,l}|^2 \quad (13)$$

In (12) and (13), it is noted that the number of interferers consisting of (12) and (13) is smaller than that of conventional NOMA system, because all users are divided into two groups. Therefore, both $I_{i,e}$ and $I_{i,r}$ are reduced, which can mitigate the performance degradation.

$I_{i,e}$ is the net power of users not participating in SIC in the receiver of the j-th user in Group i, so it always occurs and causes performance degradation. On the other hand, $I_{i,r}$ depends on the SIC performance. In perfect SIC, $\hat{x}_{i,l}$ is always the same as $x_{i,l}$ (i.e., $|x_{i,l} - \hat{x}_{i,l}|^2 = 0$), so $I_{i,r} = 0$. In other words, there is no residual interference. However, in case of imperfect SIC, the probability of $\hat{x}_{i,l} \neq x_{i,l}$ occurs and

$I_{i,r} \neq 0$. Here, we let $\mathbf{E}\left[|x_{i,l}-\hat{x}_{i,l}|^2\right]=\sigma^2$, then $I_{i,r}=\sigma^2\sum_{l=j+1}^{K/2}P_{i,l}|h_{i,j}|^2$. $\mathbf{E}[\]$ means the expectation operator. As for an excellent SIC performance such as iterative SIC and turbo SIC, the value of σ^2 is small. On the other hand, as for poor SIC performance such as linear SIC, the value of σ^2 increases.

The throughput of the j-th user in Group i, $R_{i,j}$, is

$$R_{i,j}=\frac{W}{2}\log_2\left(1+\frac{P_{i,j}|h_{i,j}|^2}{\sum_{l=1}^{j-1}P_{i,l}|h_{i,j}|^2+\sigma^2\sum_{l=j+1}^{K/2}P_{i,l}|h_{i,j}|^2+\sigma_n^2}\right)\tag{14}$$

Compared with (6), $\frac{1}{2}$ is multiplied to the pre-log term because each user utilizes the half of the entire bandwidth in the grouping-based NOMA.

Based on (14), the total throughput, R , can be obtained

$$R=\sum_{i=1}^2\sum_{j=1}^{K/2}R_{i,j}\tag{15}$$

3.4 Hybrid Operation of Conventional and Grouping-based NOMA Systems

In (14), each user of the grouping-based NOMA utilizes the half of the entire bandwidth, so $\frac{1}{2}$ is multiplied to the pre-log term. It could cause the performance degradation. If the number of users is small and $I_{i,r}$ is also small due to small σ^2 , the throughput loss due to inter-user interference and the residual interference is not dominant. In this case, the performance of the grouping-based NOMA is worse than that of the conventional NOMA. On the other hand, if the number of users is large and $I_{i,r}$ is high due to large σ^2 , the throughput will be severely degraded due to inter-user interference and the residual interference. In this case, by reducing the number of the interferers via the grouping-based NOMA, the throughput degradation can be mitigated.

Therefore, the total throughput can be enhanced through a hybrid operation of conventional and grouping-based NOMA systems according to the interference power. That is, the grouping-based NOMA system operates if $\mathbf{E}\left[R_{i,j}\right]>\mathbf{E}\left[R_k\right]$.

On the other hand, if $\mathbf{E}\left[R_{i,j}\right]<\mathbf{E}\left[R_k\right]$, the conventional NOMA system operates. As a result, the total throughput can be enhanced.

4. SIMULATION RESULTS

In this section, we compare sum rates OMA and conventional NOMA systems with the proposed grouping-based NOMA system according to the values of the total transmission power, the number of the total users and the residual interference power. Parameters that we consider for simulation is shown in Table 1.

Table 1. Simulation Parameters

Parameters	Values
R (cell radius)	500m
P (Total transmission power)	33dBm / 40dBm
K (Number of the total users)	Up to 40
Path loss	128.1+37.6log(r) dB r is distance in km
Instantaneous fading	Rayleigh fading
Noise power	-169 dBm/Hz
W (Bandwidth)	180kHz

Fig. 2 shows the sum rate comparison of OMA, NOMA and grouping-based NOMA systems when the total transmission power is 33dBm, which means relay or small cell network. The sum rate of OMA is constant, irrespective of the number of the total users. In Fig. 2, GNOMA denotes grouping-based NOMA. OMA users exclusively utilizes bandwidth, so bandwidth per user is reduced, as the number of the total users increase. As a result, the sum rate is constant. On the other hand, in case of perfect SIC, sum rates of NOMA and grouping-based NOMA increases, as the number of the total users increases. It is because both systems can enhance the spectral efficiency due to sharing the frequency resource, as the number of the total users increases.

However, in case of imperfect SIC, sum rates of both system do not increase even though the number of users increases, because the residual interference due to imperfect SIC also increases, resulting in performance degradation. In NOMA, if the error variance, σ^2 , is bigger than 10^{-5} , the sum rate of NOMA is less than that of OMA.

In case of perfect SIC, NOMA outperforms grouping-based NOMA when the number of the total users are small. Because residual interference does not exist, NOMA where all users share all resource can guarantee the higher spectral efficiency. However, if the number of users is more than 15, grouping-based NOMA outperforms NOMA, because inter-user interference increases. By splitting SINR degradation due to inter-user interference into two groups, grouping-based NOMA shows the higher spectral efficiency. This tendency is more obvious as the SIC error increases.

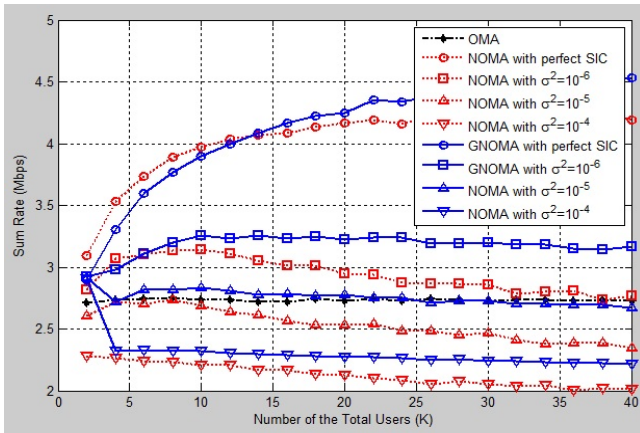

Fig. 2. Sum rate comparison of OMA, NOMA and grouping-based NOMA when the total power is 33dBm.

When SIC error exists, the residual interference causes the drastic reduction of NOMA performance. However, by splitting residual interference power due to the SIC error into two groups, grouping-based NOMA can mitigate the performance degradation. In case of $\sigma^2 = 10^{-6}$, when the number of users is more than just 6, grouping-based NOMA shows better performance. In case of σ^2 , the sum rate of OMA is higher than that of NOMA, which means NOMA cannot be applied, whereas grouping-based NOMA still outperforms OMA as well as NOMA.

Fig. 3 shows the sum rate comparison of OMA, NOMA and grouping-based NOMA systems when the total transmission power is 40dBm, which means macro cell network. The higher total transmission enables higher received signal power, compared with Fig. 2, so the region where NOMA outperforms grouping-based NOMA is wider. In case of perfect SIC, until the number of users increases up to 40, the sum rate of NOMA is better than that of grouping-based NOMA. Under the environment with no the residual interference, even though inter-user interference increases, the received SINR is still better than that of grouping-based NOMA due to higher total transmission power. Therefore, NOMA outperforms grouping-based NOMA in perfect SIC.

However, once the residual interference due to imperfect SIC exists, grouping-based NOMA is better than NOMA. In case of $\sigma^2 = 10^{-6}$, when the number of users is more than 6, grouping-based NOMA outperforms NOMA. It is because the residual interference drastically increases as the number of users increases in spite of higher transmission power. Therefore, under the environment with the residual interference due to SIC error, grouping-based NOMA can mitigate the performance degradation and guarantee higher performance than NOMA.

Based on Fig. 2 and 3, due to the transmission power, the number of users and the value of σ^2 , a hybrid operation of conventional NOMA and the grouping-based NOMA systems enables to maintain the best performance.

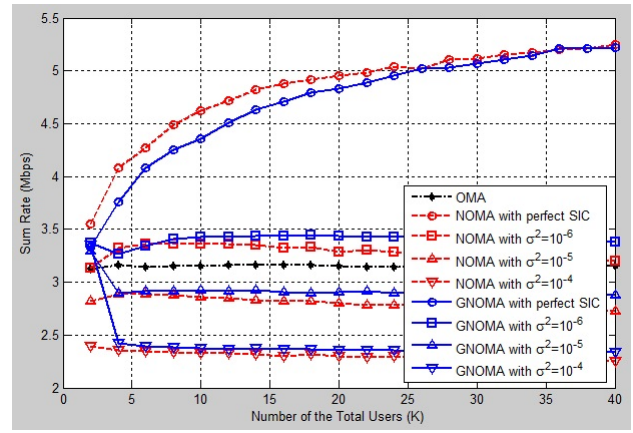

Fig. 3. Sum rate comparison of OMA, NOMA and grouping-based NOMA when the total power is 40dBm.

5. CONCLUSIONS

In this paper, we propose the grouping-based NOMA system, where all users are divided into two groups based on the distance. As the number of users is more, the SIC error is bigger and the transmission power is less, the total interference drastically increases in conventional NOMA, resulting in performance degradation. The proposed grouping-based NOMA system can mitigate the throughput loss by splitting the total interference into two groups at the cost of spectral efficiency. Because each user in the grouping-based NOMA utilizes the half of the entire bandwidth, the proposed scheme could show worse performance than the conventional NOMA in case of small number of users, high transmission power and the small SIC error. However, in the practical and general environment where many users try to share the resource with the small transmission power when SIC error exists, the grouping-based NOMA outperforms the conventional NOMA system.

ACKNOWLEDGEMENT

The research was supported by a grant from the Academic Research Program of Korea National University of Transportation in 2014.

REFERENCES

- [1] R. Andrew, "2020: The Ubiquitous Heterogeneous Network Beyond 4G," ITU Kaleidoscope, 2011.
- [2] Qualcomm Incorporated, "The 1000x Data Challenge," June 2013. Available website: <http://www.qualcomm.com/1000x/>
- [3] RWS-120052, "Report of 3GPP RAN Workshop on Release 12 and Onwards," 3GPP Workshop on Release 12 Onwards, Ljubljana, Slovenia, June 11-12, 2012.
- [4] NTT DoCoMo, "Requirements, candidate solutions & technology roadmap for LTE12 onward," 3GPP

Workshop on Rel. 12 and onwards, Ljubljana, Slovenia, June 11-12, 2012.

- [5] Sharp corporation, "Evolving RAN Towards Rel-12 and Beyond," RWS-120039, 3GPP RAN Workshop on Release 12 Onward, Ljubljana, Slovenia, 11-12 June, 2012.
- [6] Marie-Rita Hojeij, J. Farch, C. A. Nour, and C. Douillard, "Resource Allocation in Downlink Non-orthogonal Multiple Access (NOMA) for Future Radio Access," Proc. IEEE Vehicular Technology Conference (VTC)-spring, May 2015.
- [7] K. Higuchi, Y-C. Wu, and S. Aissa, "Non-orthogonal Opportunistic Beamforming: Performance Analysis and Implementation," IEEE Transactions on Wireless Communications, vol. 11, no. 4, 2012, pp. 1424-1433.
- [8] Y. Hayashi, Y. Kishiyama, and K. Higuchi, "Investigations on Power Allocation Among Beams in Nonorthogonal Access with Random Beamforming and Intra-beam SIC for Cellular MIMO Downlink," Proc. IEEE VTC-fall, Sep. 2013.
- [9] B. Kim, S. Lim, H. Kim, S. Suh, J. Kwun, S. Choi, C. Lee, S. Lee, and D. Hong, "Non-orthogonal Multiple Access for Multiuser Downlink Beamforming System," Proc. IEEE Military Communications Conference (MILCOM), Nov. 2013.
- [10] S. Tomida and K. Higuchi, "Non-orthogonal Access with SIC in Cellular Downlink for User Fairness Enhancement," Proc. International Symposium on Intelligent Signal Processing and Communication Systems (ISPACS), Dec. 2011.
- [11] Y. Saito, A. Benjennour, Y. Kishiyama, and T. Nakamura, "Evaluation of Downlink System-level Performance for Non-Orthogonal Multiple Access (NOMA)," IEICE Technical Report, RC 2012-325.
- [12] N. Otao, Y. Kishiyama, and K. Higuchi, "Performance of Non-orthogonal Access with SIC in Cellular Downlink Using Proportional Fair-based Resource Allocation," Proc. IEEE ISWC, 2012.
- [13] A. Benjebbour, Y. Saito, Y. Kishiyama, A. Li, A. Harada, and T. Nakamura, "Concept and Practical Considerations of Non-orthogonal Multiple Access (NOMA) for Future Radio Access," Proc. IEEE ISPACS, Nov. 2013.
- [14] D. Tse, P. Viswanath, *Fundamentals of Wireless Communication*, Cambridge University Press, 2005.



Kyunbyoung Ko

He (corresponding author) received the B.S., M.S., and Ph.D. degrees in Electrical and Electronic Engineering at Yonsei University, Seoul, Korea in 1997, 1999, and 2004, respectively. From March 2004 to February 2007, he was a senior engineer in Samsung Electronics, Suwon, Korea where he developed Mobile WiMAX systems for broadband wireless services. Since March 2007, he joined the Department of Control and Instrumentation Engineering at Korea National University of Transportation as an Associate Professor. His current research interests include the field of wireless communications focusing on multicarrier and multi-antenna systems, cooperative relaying, and ITS.

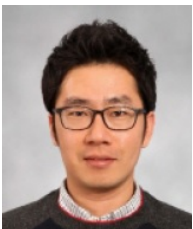

Sungmook Lim

He received the B.S. and Ph.D. degrees in Electrical and Electronic Engineering at Yonsei University, Seoul, Korea in 2005 and 2012, respectively. From September 2012 to March 2014, he was a Postdoctoral Fellow at Yonsei University where his research interests were in 5G wireless communications. Since March 2014, he joined the Department of Electronics Engineering at Korea National University of Transportation as an Assistant Professor. His current research interests include the field of 5G wireless communications focusing on multicarrier and multi-antenna systems, cooperative relaying, and ITS.