

# **A Design of Simple and Precision Direction Finder with a Combination of an Amplitude Measurement and Phase Measurement.**

**Joong-Soo Lim\***

Division of Information and Communications,  
Cheonan University, Cheonan, Korea  
Radiowave Detection Research Center, KAIST, Korea

## **ABSTRACT**

*This paper describes a design of simple and precision direction finder that can be adapted to shipboard or mobile vehicles used for Electronic support measure, ELINT and radio signal monitoring systems. The direction finding technology has improved with monolithic integrated circuit, linear array antennas, and interferometer. Interferometer uses the phase-comparison principle and has a good direction finding accuracy but it has an ambiguity problem. We suggest a simple ambiguity solver using phase-comparison technology with amplitude-comparison principle. The direction finding device that has been designed by the suggested method has 0.7 degree RMS error in azimuth angle and 0.6 degree RMS error in elevation angle in 0.5 - 2.0 GHz.*

**Keywords:** *phase-comparison, direction finding, amplitude-comparison, ambiguity, interferometer.*

## **1. INTRODUCTION\***

This paper describes a simple and precision device to find the direction of the microwave signal sources using electronic intelligence(ELINT), electronic warfare support(ES) or Radio Frequency(RF) monitoring systems which can be set on ground, shipboard or mobile vehicles. This technology uses a combination of the amplitude-measurement technology which use the amplitude difference of the RF signal received by the array antennas and the phase-measurement technology which use the phase difference of the RF signals received by the same array antennas.

A direction finding technology was stated to find the direction of the signal source by using the horn antenna or a parabolic antenna that had a narrow beam width and high gain. We rotated the antenna with respect to the azimuth angle or elevation angle that we wanted to monitor and measure. Nowadays, since the array antenna technology and phase-comparison technology are advanced, the amplitude comparison method or phase comparison method is used for a direction finding(DF) of microwave signals.

Generally, a phase-comparison technology has better DF accuracy than amplitude-comparison technology when the direction of the signal that comes from the same angle range is measured using the same number of array antennas, because phase-comparison method is robust to noise parameters. But it has an ambiguity angle problem that they indicate the 2nd, 3rd harmonic direction angles simultaneously. An example of the suggested technology is

designed to place 8 array antennas in a 45° distance around the 360° circle. Also it is designed to use the phase-difference of the received signal from two nearby antennas to measure the incident signal direction accurately and to use the amplitude-difference to eliminate the direction ambiguity.

## **2. TECHNICAL ANALYSIS**

### **2.1 Amplitude-comparison Direction Finding**

The principle of the amplitude-measurement technology is shown in Fig. 1. Number 1 antenna is set on  $-\alpha$  azimuth angle and number 2 antenna is set on  $+\alpha$  azimuth angle.  $G_1(\theta)$  is the antenna beam pattern of number 1 antenna, and  $G_2(\theta)$  is the antenna beam pattern of number 2 antenna. When a RF signal comes from 0 degree in Fig. 1, the received signal amplitude of antenna 1 is same to that of antenna two. But when a RF signal comes from  $-\alpha$  azimuth angle, the received signal amplitude of antenna 1 is larger than that of antenna two. If we know the beam pattern of two antennas, we can calculate the incident angle to measure the amplitude of incident RF signal.[1][2]

### **2.2. Phase -comparison Direction Finding**

The interferometer method is a way to find out the direction of incident RF signal by setting up the antennas at different positions and measuring the phase differences of same coming signals. When the interval of two antennas is  $D$  and the signal incidence direction is  $\theta$ ,  $\lambda$  is the

\*Corresponding author. E-mail: [jslim@cheonan.ac.kr](mailto:jslim@cheonan.ac.kr)

Manuscript received Sep. 15, 2005 ; accepted Oct. 25, 2005.

wavelength of the incidence signal.  $\phi$  is the phase difference of RF signals measured at the two antennas with the interval of  $D$  in Fig. 2. We can calculate the signal incidence direction ( $\theta$ ) with Eq. (1).[3]

$$\phi = \frac{2\pi}{\lambda} D \cdot \sin \theta \tag{1}$$

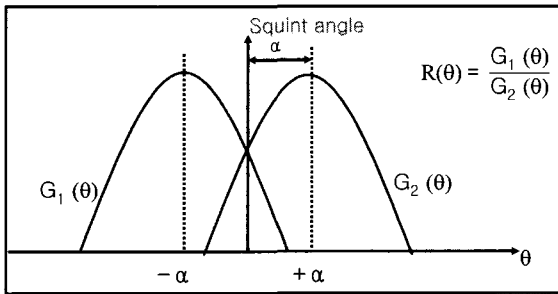

Fig. 1. Principle of amplitude-measurement DF technology.

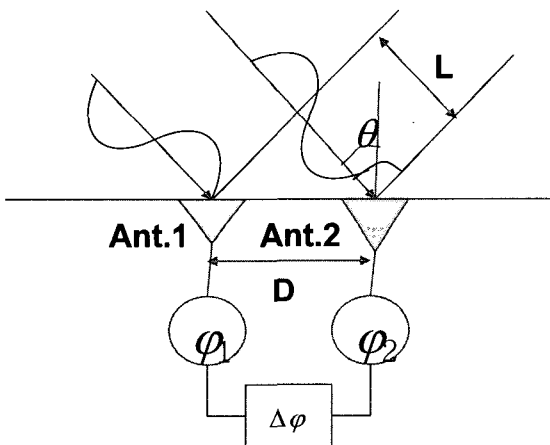

Fig. 2. Principle of interferometer DF technology.

**2.3 Multi-baseline Phase-comparison Direction Finder**

To measure the incidence angle more accurately, we can enlarge the distance ( $D$ ) with  $2\lambda$ ,  $3\lambda$  or  $4\lambda$  in Fig. 3. However an ambiguity occurs when  $D$  become larger than  $\lambda$  that is  $\phi > 2\pi$ . Multi baseline interferometer system is developed to eliminate the ambiguity that have many interferometer sets of different baselines ( $D_1, D_2, \dots, D_n$ ). In multi-baseline, phase-difference from  $D_n$  baseline is used to get a precision direction angle in Eq. (2) and the rest of the phase differences of other baseline ( $D_1, D_2, \dots$ ) are used to solve the ambiguity together.

$$\phi_n = \frac{2\pi}{\lambda} D_n \cdot \sin \theta \tag{2}$$

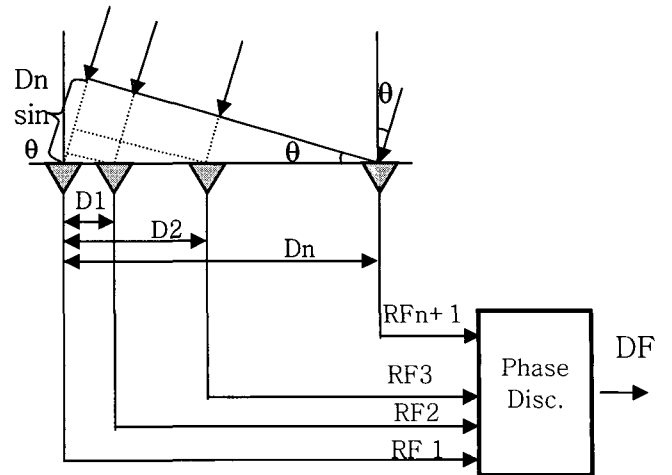

Fig. 3. A block diagram of multi baseline D.F. system.

**3. THE PRINCIPLE OF A COMBINATION TECHNOLOGY FOR AMPLITUDE-MEASUREMENT AND PHASE-MEASUREMENT.**

**3.1 A Design of a Simple and Precision Direction Finder**

As above mentioned, the multi baseline interferometer system measures the direction of incident signal accurately but it is very complicated and large in size to solve ambiguity. This paper suggests new technology to calculate the direction accuracy with long baseline interferometer and to solve the ambiguity with same long baseline interferometer antenna array.

The principle of this technology is to use amplitude-difference and phase-difference together from the same baseline antenna array. Fig. 4 and Fig. 5 are the block diagram of combination DF system that has 8 array antennas on  $360^\circ$  azimuth angle and base line is  $3\lambda$ . Each baseline between two antennas is used to cover  $45^\circ$  in azimuth angle and  $3\lambda$  is for good DF angle.

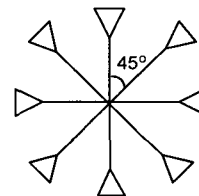

Fig. 4. A eight antenna array for azimuth direction Finder.

RF source signal is arrived at 8 antennas with phase difference and amplitude difference, then the RF signals of antennas are divided into two channels. Amplitude-difference measurement channel calculates the incident directions of RF signals roughly with amplitude comparison of antenna signals and phase-difference measurement channel calculate the incident direction of RF signals accurately with phase

comparison of the same antenna RF signals while phase-comparison method have an angle ambiguity problem. A combination technology of amplitude-measurement and phase-measurement can eliminate the ambiguity and make an accurate DF angle without ambiguity.

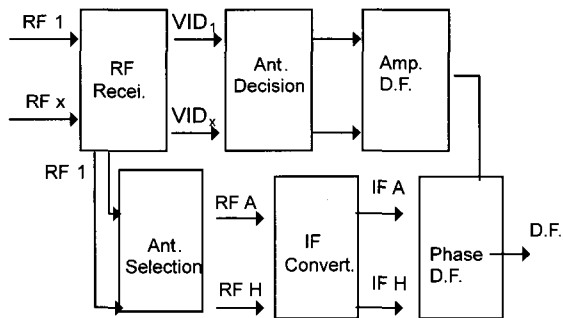

Fig. 5. The block diagram of combination DF Receiver.

### 3.2. A Principle of Ambiguity Elimination

Fig. 6 shows the principle how the ambiguity is eliminated. If a baseline of phase-comparison direction finder is  $3\lambda$  and is fixed to operate in  $60^\circ$  azimuth angle, the azimuth angle ambiguity of phase difference occurs every  $20^\circ$  and the azimuth angle ambiguity of amplitude difference is zero in Fig. 6. Phase comparison method has a better direction finding accuracy because  $360^\circ$  phase-difference of incident signals is adopted to  $20^\circ$  azimuth angle comparing to amplitude-difference method. The ambiguity problem of phase-difference measurement circuit can be solved by combination with amplitude-difference method in Eq. (3) and (4). Using the IF narrow band phase difference measurement circuit in Fig. 5, it is possible to get a precise direction finding accuracy in Eq. (4).

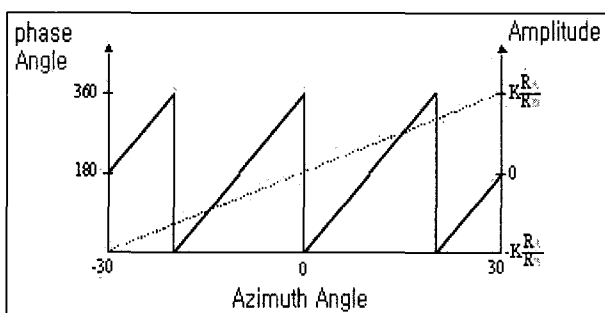

Fig.6. Amplitude and phase difference in  $60^\circ$  azimuth angles.

The suggested design is very simple compare to multi-base line method in Fig. 3 and has the same DF accuracy. Only two near antenna channels are needed to make an interferometer in a given azimuth angle in this suggested in Fig. 5, the signal processing channels are greatly decreased and much more economical compared to the linear array multi-base line interferometer. Solving the ambiguity problem in interferometer technology has a close relationship with the distance of nearby antennas in Fig. 4. The distance

of nearby antennas is the distance of base line of interferometer. The number of ambiguity occurrence (k) is depends on the interval of each antenna and the receiving azimuth angel. When  $3\lambda$  is the set up interval and  $60^\circ$  is azimuth angle receiving range in the suggested device, k become 3.[4][5]

After deciding ambiguity number (k), Eq. (3) is used to calculate the real direction. In a multi interferometer devices, the truth table in terms of  $\phi_1, \phi_2, \dots, \phi_n$  are used to find k. Calculate the direction that has an ambiguity which is  $\theta_k |_{k=0,2}$  by using Eq. (3). After comparing  $\theta_k$  and the amplitude comparison results using Eq. (4), the final output would be  $\theta_k$  that has the lesser difference and it will be used to solve the ambiguity problem. [6].

$$\theta_k = \arcsin\left(\frac{\phi + 2\pi.K}{D_n \cdot 2\pi/\lambda}\right) \Big|_{k=0,2} \quad (3)$$

$$\theta = \theta_k, \text{ if } \frac{\theta_{k-1} + \theta_k}{2} < \theta_{amp} < \frac{\theta_k + \theta_{k+1}}{2} \quad (4)$$

### 4. TEST RESULTS AND CONCLUSIONS

The direction finder has been designed and made by the suggest technology and the DF angle error simulated in 0.5 – 2.0 GHz is under  $0.2^\circ$  while signal to noise ratio is 40 dB. The direction finder that is made by the suggested design is tested in anechoic chamber through 0.5 – 2.0 GHz in Fig. 7 and the measurement direction error is less than  $0.7^\circ$  in azimuth angle and  $0.6^\circ$  in elevation angle in Fig. 8. The direction finding device that is developed using amplitude-measurement and phase-measurement is a simple configuration and have a small direction finding error, and can be directly adapted to shipboard or land base ES, ELINT systems, and mobile stations for monitoring the electromagnetic waves.[7][8]

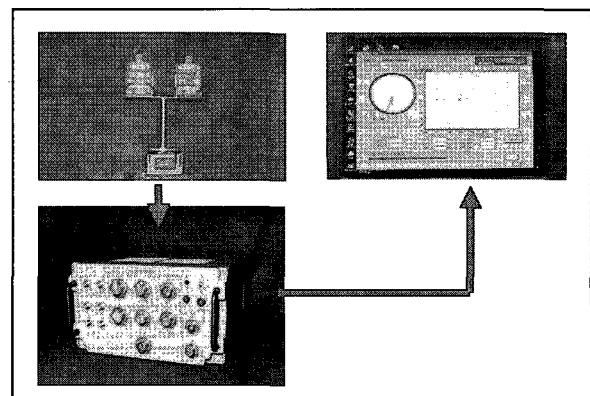

Fig. 7. The DF error measurement in anechoic chamber.

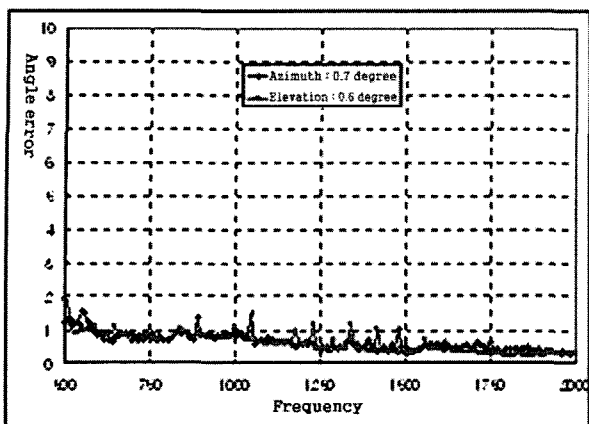

Fig. 8. The measurement results of DF accuracy in L-band.

### REFERENCES

- [1] D. Curtis Schleher, **Electronic Warfare in the Information Age**: Artech House, 1999.
- [2] James Bao-Yen Tsui, **Digital Microwave Receivers**: Artech House, 1989.
- [3] Stephen E. Lipsky, **Microwave Passive Direction Finding**: John Wiley & Sons, 1987.
- [4] "Interferometer Direction Finding System", **Journal of electronic defense**, Vol. 18, No. 3, 1995.
- [5] "Distance-Measuring and Interferometric Techniques", **Journal of electronic defense**, Vol. 25, No.11, 2002.
- [6] J. S. Lim, C. G. Jung and G. S. Chae, "A Design of Precision RF Direction Finding Devices Using Circular Interferometer", **2004 International Symposium on Intelligent Signal Processing and Communication Systems**, Nov. 18-19, 2004, IEE, . pp 713-716
- [7] E. Boch and M. Stapleton. "Direction-Finding Performance of a ka-Band ESM Receiver", **1994 Microwave and Guided Wave Letters 4.1** (Jan.1994{MGWL}):9-10.
- [8] S. Rehmark "Instantaneous Bearing Discriminators with Omni directional coverage and High Accuracy", **1980 MTT- International Microwave Symposium Digest 80.1**, pp 120-122.



#### Joong-Soo Lim

He received the B.S., M.S. in electrical Engineering from Kyung-book university, Choong-Nam University, Korea in 1978, 1987 and also received Ph.D. in electrical engineering from Auburn university, USA in 1994. He worked at Agency for

Defense Development from 1994 to 2002 as principal researcher. Since then, he has worked for Cheonan university as professor, Korea. His main research interests include numerical analysis, direction finding, radar, EW and RF system design.