



Print ISSN: 1738-3110 / Online ISSN 2093-7717  
JDS website: <http://www.jds.or.kr/>  
<http://dx.doi.org/10.15722/jds.21.08.202308.35>

## Factors Affecting the Intention to Distribute in Sort Plastic Waste of Vietnamese People: A Case Study in Ho Chi Minh City

Thai Dinh TRUONG<sup>1</sup>, Thich Van NGUYEN<sup>2</sup>

Received: August 17, 2022. Revised: July 21, 2023. Accepted: August 05, 2023.

### Abstract

**Purpose:** This paper (1) identifies the factors that affect people's changing habits towards waste sorting, (2) evaluates the benefits of waste sorting to the environment and (3) designs communication strategies to change people's behavior and habits in sorting plastic waste in Ho Chi Minh City, Vietnam. **Research design, data and methodology:** Using the data from 309 people that are living in Ho Chi Minh City and Structural Equation Modeling (SEM), to evaluate variables and test the hypotheses. **Results:** Research results show that attitudes, subjective standards, behavioral control, and facilities affect people's intention to classify plastic waste. We find that environmental concerns greatly influence people's attitudes. In contrast, environmental concerns have a relatively weaker effect on people's degree of behavioral control. **Conclusion:** Environmental protection is a matter of concern in the world. In Vietnam, this issue has been institutionalized into law to create a basis for improving the effectiveness of environmental protection activities. This article has some limitations. Firstly, sample is limited to HCMC residents; the study results are not representative of the entire population of Vietnam. This paper is based on cross-sectional data, which is not the best way to establish a causal relationship between the intention to sort plastic waste and its drivers.

**Keywords:** Plastic waste, Plastic waste classification, Environmental awareness, and Distribute.

**JEL Classification Code:** Q53, D21, C10

### 1. Introduction

Awareness of the dangers of waste negatively affecting the environment has become a top concern of people in Vietnam, especially in big cities with high awareness. In a previous study by (Nguyen et al., 2020) conducted a questionnaire survey with 300 Vietnamese people "Mention three main types of environmental pollution in Vietnam, with the question in your opinion, which type of waste has the greatest level of danger and negative impact on the

environment and your health?". Respondents ranked plastic waste as the most hazardous that affects both the natural environment and human health, followed by waste from industrial plants and, finally, from manufacturing and agricultural production. Concerns about environmental pollution and potential risks to human health have persisted throughout the past time. However, there have been many changes in environmental quality through changes in people's awareness as well as changes in regulations on waste management and control in Vietnam.

1 First Author. PhD, Lecture at Faculty of Business Administration, Ho Chi Minh University of Banking, Vietnam.

2 Corresponding Author. PhD, Deputy Director of Institute of Scientific Research and Banking Technology, Ho Chi Minh University of Banking, Vietnam, Email: [thichnv@hub.edu.vn](mailto:thichnv@hub.edu.vn).

© Copyright: The Author(s)

This is an Open Access article distributed under the terms of the Creative Commons Attribution Non-Commercial License (<http://creativecommons.org/licenses/by-nc/4.0/>) which permits unrestricted noncommercial use, distribution, and reproduction in any medium, provided the original work is properly cited.

Hazard awareness of different types of waste plays a vital role in promoting people's waste segregation behaviour (Guerrero et al., 2013). With the rapid development of today's society, more and more waste is generated, which means that a large amount of waste is generated every year, and its increase creates unexpected harm. Therefore, separating and recycling waste is essential to reduce the source of hazardous waste, especially plastic waste. Most of the household waste can be sorted right at the household. However, people's mentality is that the garbage classification is done by the waste management unit (Lozano & Vallés, 2007). Therefore, changing people's awareness and behavior of waste separation at home will help reduce the amount of solid waste that goes to landfills to improve environmental quality and can obtain great economic benefits from recyclable and reusable wastes. Many previous studies have made in-depth and comprehensive assessments of the ecological efficiency of waste separation at home (Knickmeyer, 2020). The results show that separating waste at home will reduce the risk of pollution and minimize the residual waste from human activities and production (Klemeš et al., 2020). However, these studies focus on changing household waste sorting habits that contribute to environmental protection in developing countries is still limited. Therefore, in this study, we will focus on addressing this gap.

People living in developing countries like Vietnam are worried about environmental quality issues related to waste management and control, especially the unsorted behavior of people (Omran et al., 2008). In Ho Chi Minh City, about 14 million people and up to 80 tons of plastic waste is discharged into the environment daily. However, awareness of the benefits of household waste separation has not been paid enough attention, which has limited the implementation of waste classification by people in some areas (Knickmeyer, 2020). International experience shows that a high level of awareness about the benefits of household waste sorting will immediately positively affect the quality of people's living environment (K. Kim et al., 2013). Previous studies on the factors influencing behavior change for segregating waste at source have not been conclusive. Therefore, this study aims to consider the factors that change the behavior in the classification of plastic waste before they are collected and treated in Ho Chi Minh City, Vietnam. First, this study identifies the factors affecting people's changing habits in waste sorting in Ho Chi Minh City and evaluates and analyzes the benefits of waste sorting to the environment. Then, these results will allow environmental managers to design communication strategies to change people's behavior and habits in sorting plastic waste at home to minimize the negative impact on the environment.

## **2. Literature Review**

Plastic waste is a substance that is very difficult to decompose in many environments, most of which are single-use plastic products; the most common are: plastic bags, plastic bottles, plastic boxes, straws, and food packaging (An et al., 2020). Plastic waste includes polyethylene (PE) plastic packaging that becomes waste after use. In household waste, other types of plastic also contain waste plastics. Plastic waste is a mixture of plastic; most is PE plastic. Plastic waste contains harmful chemicals that pollute the environment and seriously affect economic growth, global climate change, and social life (Jalil et al., 2013).

### **2.1. Environmental Knowledge**

Environmental knowledge can be defined as general knowledge of facts, concepts, and relationships related to the natural environment and its major ecosystems. Therefore, environmental knowledge refers to what people know about the environment, the key relationships that lead to environmental aspects or impacts, and the collective responsibility necessary for sustainable environmental sustainability (Fryxell & Lo, 2003). People are a vital force for environmental protection. Therefore, raising awareness and action of this target group is necessary. People's awareness of environmental issues can be enhanced via education (Chow et al., 2017). People with environmental knowledge and skills will be more motivated to participate in environmental protection activities (Tali Tal, 2004), thereby generating new ideas to solve environmental problems.

### **2.2. Theory of Planned Behavior**

Theory of Planned Behavior (TPB) (Ajzen, 2011) is often used to support and provide information about the effectiveness of public perceptions and attitudes. TPB delivers a theoretical framework for assessing pro-environmental behaviors and identifies factors influencing intentions to segregate plastic waste systematically. The TPB theory is developed from the earlier Theory of Reasoned Action (TRA). While TRA assumes that people behave rationally, TPB hypothesizes that the determinant of behavior is an individual's intention to perform or not to perform the behavior. The intention is, in turn, influenced by two factors, attitudes, and subjective norms. Luo et al. (2020) argues that the performance of many behaviors will be limited by the lack of appropriate opportunities, skills, and resources. This is why TPB extended TRA to include a third variable, behavioral control, a measure of an individual's perception of their ability to perform a behavior. TPB has been used in many studies to understand a range of

environmentally responsible behaviors, including plastic recycling (Kelly, 2002). It can be seen that the more favorable the attitudes and subjective norms and the greater the cognitive control, the stronger the intention to perform the behavior.

This study uses TPB as the background theory and, at the same time, adds some variables suitable to the research context to investigate the intention of people to sort plastic waste. Approaches include environmental concern (EC), attitude (AT), subjective norm (SN), and behavioral control (PB) that can influence people's intention to perform specific behavior toward sorting plastic waste in daily life.

### 2.3. Determinants of Waste Segregation Behavior

Sorting plastic waste is a significant job in waste management. A major challenge in the plastics recycling industry is sorting plastics by type and color, which can help reduce the risk of segregation of high-grade recycled plastics into non-recyclable low-grade plastics. Manual sorting of plastic waste involves identifying the plastic's shape, color, appearance, and brand to distinguish it (Sreekumar et al., 2009). Manual classification is laborious; this behavior is realized through factors acting on it based on the theory of extended planned behavior (Lejuez et al., 2001).

They perceive environmental influences as a social or cultural construct (Hudek et al., 2021). The factors influencing people's waste segregation can vary from region to region. These differences are caused by differences in social communication, cultural attainment, and infrastructure across regions (Lejuez et al., 2001). Some studies have concluded that residents of urban areas perceive a higher risk of environmental pollution and are more interested in household waste separation activities than residents of rural areas (Stern et al., 1996). Therefore, there are significant environmental perception differences among people living with different socioeconomic characteristics. Consumers often do not have adequate knowledge about the harmful effects of plastic waste on the environment, so communication about the detrimental effects of plastic waste from organizations is also an important psychological factor affecting the environment's intention to segregate waste at its source (Stern et al., 1996). Experimental studies by (Lobb et al., 2010) showed a positive relationship between the communication of organizations and authorities and the perception of waste classification before discharging into the environment citizen. The study of (ABC) concluded that there is a significant influence of some demographic variables such as age, education level, income level, and the presence of children on the perception of pollution environment. Domestic waste is one of the significant sources of environmental pollution in urban areas. Therefore,

the classification of hazardous waste in households represents the best control for environmental pollution.

### 2.4. Relationship between Environmental Concerns and TPB Structures

According to Gill et al. (1986), environmental concern refers to the general perception of environmental protection. Diamantopoulos et al. (2003) argue that environmental concerns have proven to be an essential basis in research on environmental management. Individuals with a serious concern for the environment are more likely to take action for the environment. In this study, it is assumed that environmental concerns influence TPB structures. Therefore, the following hypotheses are proposed:

- **H1a:** Environmental concerns positively influence attitudes towards plastic waste classification.
- **H1b:** Environmental concerns positively influence subjective norms in the classification of plastic waste.
- **H1c:** Environmental concerns positively influence behavioral control in sorting plastic waste.

### 2.5. Relationship between TPB Structures and Intent to Sort Plastic Waste

The intention is a factor used to evaluate the ability to perform a behavior in the future and is a motivating factor, motivating an individual to be willing to perform a behavior. The intention is directly influenced by "attitude.", "subjective norm" and "behavioral control" (Ajzen, 2011). Attitude is an individual's assessment of the results obtained from performing a behavior. In this study, the attitude towards plastic waste classification is a psychological assessment derived from each individual's perception. If individuals have a positive attitude towards waste segregation, they will form an intention to sort plastic waste. Subjective norm is an individual's perception of societal pressures to perform or not to perform a behavior (Ajzen, 2011). Accordingly, the subjective norm is a social attribute in which the things that individuals consider whether to do or not depend on the opinions and views of others. Perceived behavioral control is defined as an individual's perception of the difficulty or ease of performing a behavior. Sraughan and Robert (1999) argue that people who care about the environment only show behavior towards the environment if they perceive that individual actions can contribute to solving common environmental problems. Based on the above, the following hypotheses are proposed:

- **H2a:** Attitude positively influences the intention to sort plastic waste.
- **H2b:** Subjective norm positively influences the intention to classify plastic waste.

- **H2c:** Behavioral control positively influences the intention to sort plastic waste.

- **H4:** Time pressure negatively affects the intention to sort plastic waste.

**2.6. The Relationship between Facilities and the Intention to Sort Plastic Waste**

Providing adequate facilities is important in determining effective waste management in urban areas (Leao et al., 2001). Improving the infrastructure of the waste management system will reinforce people's positive intentions toward waste segregation, which, if lacking, will be a barrier (Leao et al., 2001). In the process of sorting, providing better facilities will facilitate and encourage individuals to voluntarily participate in waste classification. On that basis, the following hypothesis is proposed:

- **H3:** Facilities positively influence the intention to sort plastic waste.

Based on the research hypotheses, the theoretical research model is proposed in Figure 1 below:

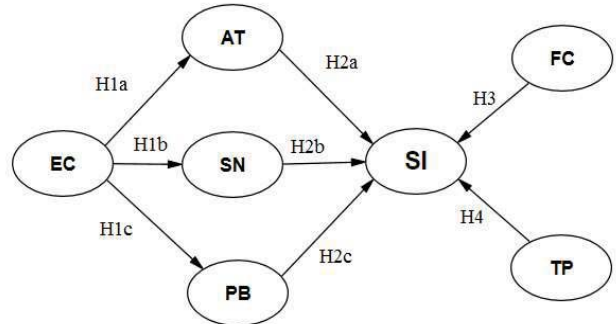

**Figure 1:** Proposed Research Model

*Of which:*

- Environmental Concern (EC)
- Subjective norms (SN)
- Facilities (FC)
- Separation Intention (SI)
- Attitude (AT)
- Perceived behavioral control (PB)
- Time Pressure (TP)

**2.7. Relationship between Time Pressure and Intention to Sort Plastic Waste**

Previous studies on waste sorting behavior have shown that conditioning factors such as time pressure are important in predicting an individual's intentions and behavior (Matiuk, 2021). Considering the context of waste classification in a learning environment, time is quite limited, while waste sorting at schools requires many steps, so it takes a lot of time. However, it helps to protect the environment. Based on this, the following hypothesis is proposed:

The related literature would be summarized in the table 1 below.

**Table 1:** The Brief Summary of some Related Studies

Year	Author(s)	Journal	Main Findings	Methodology
2018	Fan, B., Yang, W., & Shen, X.	Journal of Cleaner Production	The theory of planned behavior (TPB) is used to build a theoretical model to study anti-familial anti-solid stool behavior. From the research results, the article proposes some solutions for city waste management processes.	Empirical Study
2018	Ambrin Shahzadi, Muhammad Hussain, Muhammad Afzal, Syed Amir Gillani	International Journal of Social Sciences and Management	Study on the current status of waste treatment in rural community Lahore. The research results show that most respondents' knowledge about waste treatment is at a good or satisfactory level. Despite having good knowledge, respondents need better waste treatment practices due to poor awareness and lack of public trash cans.	Empirical Study
2019	Zhang, B., Lai, K., Wang, B., & Wang, Z.	Journal of Environmental Management	The study aimed to explore the effects of individual attitudes, access to facilities, and government stimulus on residents' residential waste segregation intentions in China. The results showed that personal norm was the main factor affecting the choice of Chinese residents. In contrast, the subjective model and perceived behavioral control did not significantly affect waste segregation.	Empirical Study
2020	Luo, H., Zhao, L., & Zhang, Z.	Waste Management	Study behaviors related to garbage sorting, bringing their shopping bags, and reusing plastic bags in China. The results show that for conduct related to plastic waste: men are affected by social norms, while women are affected by social networks. The article provides a waste management perspective from a social interaction perspective.	Empirical Study

Year	Author(s)	Journal	Main Findings	Methodology
2020	Galati, A., Sabatino, L., Prinzivalli, C. S., D'Anna, F., & Scalenghe, R.	Journal of Environmental Management	Research on strawberry production regarding the intention to recycle plastic materials and the elements that characterize these models in Marsala, Italy. The results show that if manufacturers change their perceptions, they will be better involved in improving environmental sustainability and creating a circular economy.	Empirical Study
2020	Shen, J., Zheng, D., Zhang, X., & Qu, M.	International Journal of Environmental Research and Public Health	Determining factors affecting farmers' intention to sort household waste in Guanzhong, China. Research results show that psychosocial factors determine the intention to sort household waste.	Empirical Study
2021	Negash, Y. T., Sarmiento, L. S. C., Tseng, M.-L., Lim, M. K., & Ali, M. H.	Resources, Conservation and Recycling	The study contributes to developing a cohesive set of elements to address the problem of waste disposal and to strengthen the intention to segregate waste in Ecuadorian households to increase recycling efficiency for management strategies for sustainable plastic waste.	Empirical Study
2021	Matiuk, Y., & Liobikienė, G.	Journal of Environmental Management	Study the impact of information, social, convenience, and financial tools and the actual situation on the waste sorting behavior of residents in Lithuania. The results show that financial and informational tools significantly impact garbage sorting behavior, while social and convenience tools have a negligible effect.	Empirical Study
2021	Wang, C., Chu, Z., & Gu, W.	Journal of Cleaner Production	The study aimed to determine how the information intervention affects the solid waste segregation behavior of urban residents in China. The results show that information intervention can improve behavioral attitudes, subjective norms, control cognitive behavior, and satisfaction with people's policies for solid waste classification.	Empirical Study
2021	Ossama Labib, Latifah Manaf, Amir Hamzah Sharaai and Siti Sarah Mohamad Zaid	Recycling	The study explores the possibility that the people of Dammam are willing to participate in the sorting and recycling solid waste to improve the treatment of environmental pollution. The results of the analysis of the moderator variable show a difference between the attitude and the willingness to sort and recycle waste in the low-income and high-income groups. In addition, the social influence on households' willingness to sort and recycle waste also differs by gender in men and women.	Empirical Study
2021	Roche Cerasi, I., Sánchez, F. V., Gallardo, I., Górriz, M. Á., Torrijos, P., Aliaga, C., & Franco, J.	Waste Management & Research: The Journal for a Sustainable Circular Economy	The study assessed the attitudes and attitudes of participants about plastic recycling from three European cities selected as pilot sites: Valencia (Spain), Utrecht (Netherlands), and Alba Iulia (Romania). Research results show that people have a positive attitude towards sorting recyclables at home to increase the number of recycled products. The hindering factors are the need for more awareness and knowledge of the people and the lack of facilities to utilize recyclable materials.	Empirical Study

### 3. Research Methods

#### 3.1. Data Collection

The data collected in this study were surveyed on 309 samples by online survey and structured questionnaire using a convenient sampling method. For sample size, Negash et al. (2021) proposes ten samples for one observed variable. The theoretical model includes 28 observed variables, so the minimum number of samples for the study needs 280. The number of survey samples collected and included in the analysis is 309, satisfactory. The survey subjects of the study are people living in Ho Chi Minh City. The high level of

concern about environmental safety among Ho Chi Minh City people has provided an opportunity to study the perception of plastic waste sorting about its unsafety risks and long-term effects on the environment.

#### 3.2. Methods of Data Analysis

Data were analyzed using the statistical software SPSS 20.0 and AMOS 20.0. Cronbach's coefficient  $\alpha$  is used to analyze the reliability between the observed variables in each measurement scale for the research concepts (according to the standard  $\alpha \geq 0.7$ ). Exploratory Factor Analysis (EFA) was used to test the convergent and

discriminant validity of the concepts. As suggested by Anderson and Gerbing (1988), a two-step model is used: a measurement model (performing Confirmatory Factor Analysis (CFA) to check overall reliability and conformity. The combination of observed variables with theoretical structure) and Structural Equation Modeling (SEM, to evaluate the fit of the model and test the hypothesis). Standards applied in CFA and SEM: estimated by the method of the maximum likelihood function (Maximum Likelihood), the overall fit is measured by indexes with the following criteria: GFI > 0.9; CFI > 0.9; TLI > 0.9 and RMSEA < 0.08.

## 4. Finding

### 4.1. Results of Testing the Reliability of the Scale

The results of testing the scale's reliability by Cronbach's Alpha coefficient are presented in Table 1. The scale and coding columns present the scales in the theoretical model. The initial variable column presents all the observed variables that have been coded for each respective scale. The column of retained variables shows the results of observed variables that meet the requirements of analytical techniques, the variables in the original variable column do not appear here, implying that they have been excluded because they do not meet the test standards.

**Table 2:** Summary of the results of testing the reliability of the scale

The scale – Coding	Initial variable	Retain variable	Cronbach's Alpha
AT	AT1, AT2, AT3, AT4	AT1, AT3, AT4	0,891
SN	SN1, SN2, SN3, SN4, SN5	SN1, SN2, SN3, SN4, SN5	0,898
PB	PB1, PB2, PB3, PB4	PB1, PB2, PB3, PB4	0,811
EC	EC1, EC2, EC3, EC4, EC5	EC1, EC2, EC3, EC4, EC5	0,926
FC	FC1, FC2, FC3	FC1, FC2, FC3	0,908
TP	TP1, TP2, TP3	TP1, TP2, TP3	0,764
SI	SI1, SI2, SI3, SI4	SI1, SI2, SI3, SI4	0,870

Source: Authors' calculation.

#### 4.1.1. Exploratory Factor Analysis (EFA)

The analysis is carried out in two steps: step one, analyze each independent factor to identify the contents better to be considered in the step of testing the scale's reliability. Step two uses the oblique rotation method to check the convergent and discriminant values of all variables in the model. The EFA results of all variables, using the oblique rotation method, show that the concepts in the research model have convergent and discriminant validity. The concept of attitude (AT) is the type of observed variable AT2 because it does not reach the convergent value. All remaining observed variables in the model have factor weights > 0.5. Thus, the EFA results show that the research concepts are satisfactory.

#### 4.1.2. Confirmatory Factor Analysis (CFA)

The results of the CFA analysis show that the critical model is suitable, the general goodness of fit indicators such as: Chi-Square/df = 1,511 (< 0.3); GFI = 0.904 (> 0.9); CFI = 0.971 (> 0.9); TLI = 0.966 (> 0.9); RMSEA = 0.041 (< 0.08) meets the requirement.

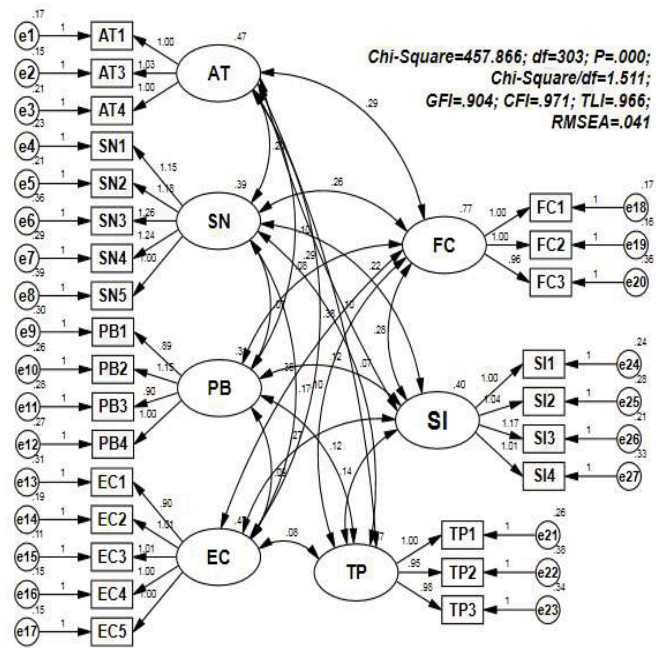

**Figure 2:** Critical CFA model

Table 3 presents a summary of the results of the reliability analysis of the scales and the extracted variance of each scale using Cronbach's Alpha coefficient, exploratory factor analysis, and confirmatory factor analysis.

The results show the similarity between the methods, the reliability of all scales is more significant than 0.7; The extracted variances of the scales are all 50% larger than the standard.

**Table 3:** Value and reliability of structures

Factors	Cronbach's Alpha	Extracted variance (EFA)(%)	Reliability	Extracted variance (AVE)(%)
AT	0,891	82,17	0,892	73,37
SN	0,898	71,28	0,899	64,38
PB	0,811	63,87	0,814	52,02
EC	0,926	77,50	0,894	72,17
FC	0,908	84,71	0,927	77,28
TP	0,764	68,03	0,765	52,34
SI	0,870	71,95	0,871	62,80

Source: Authors' calculation.

The discriminant value test results are presented in Table 4. The square root of AVE is larger than the correlation value in rows and columns; therefore, according to Fornell-

Larcker's criteria (Fornell & Larcker, 1981), the research concepts in the theoretical model satisfy the requirement of discriminant validity.

**Table 4:** Discriminant validity test (Fornell-Larcker criterion)

Structure	AT	SN	PB	E.C.	FC	TP	SI
AT	<b>0,857</b>						
SN	0,462	<b>0,802</b>					
PB	0,249	0,210	<b>0,721</b>				
EC	0,807	0,396	0,235	<b>0,850</b>			
FC	0,476	0,481	0,171	0,598	<b>0,879</b>		
TP	0,232	0,176	0,324	0,198	0,183	<b>0,723</b>	
SI	0,658	0,566	0,348	0,629	0,502	0,373	<b>0,793</b>

Source: Authors' calculation.

From the above results, the confirmatory factor analysis model meets the requirements of general relevance. The scales have aggregate reliability and appropriately extracted variance. The concepts in the research model meet the requirements meet the criteria of convergent and discriminant validity. On this basis, the linear structural model is used to test the research hypotheses.

**4.1.3. Analysis of Results of Structural Equation Modeling (SEM)**

The SEM model is suitable for testing theoretical models in which the research concepts are latent. The model includes many endogenous relationships (Hair et al., 2017). The results of the SEM analysis are shown in Figure 3.

The indicators measuring the model's overall fit all meet the technical requirements: GFI = 0.889, although slightly smaller than the standard 0.9, but still within the acceptable limits; CFI = 0.960; TLI = 0.955; RMSEA = 0.047 are all satisfactory.

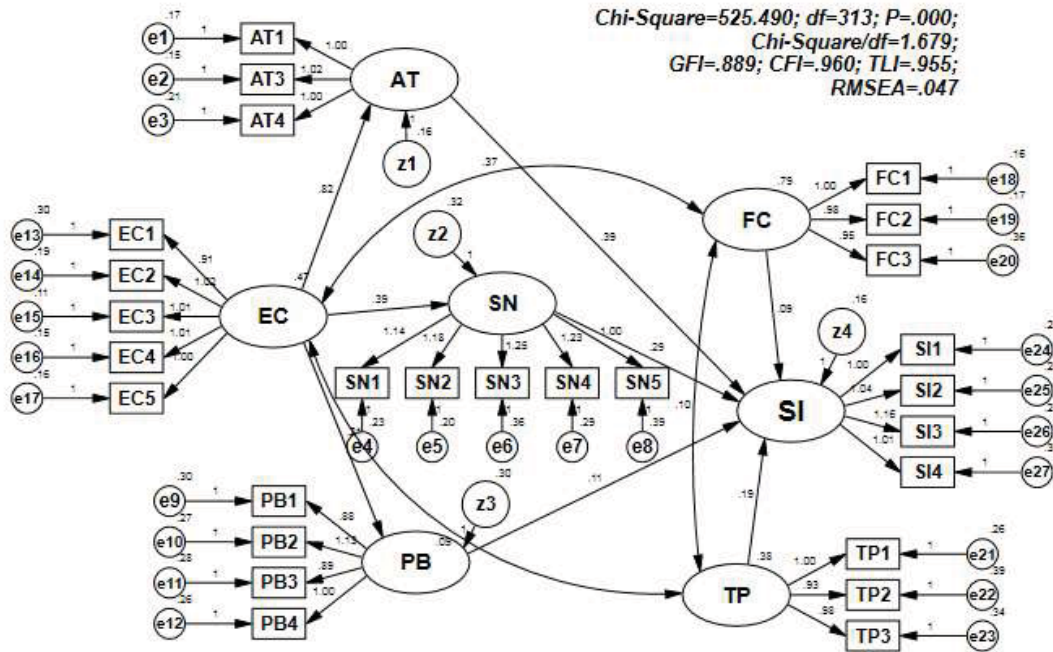

Figure 3: Research hypothesis testing by SEM

Table 5 presents the regression weights of the theoretical relationships in the research model.

Table 5: Regression Weights of Theoretical Relationships

Hypothetical relationship				Weight	S.E.	C.R.	p
$H_{1a}$	Environmental Concern (EC)	→	Attitude (AT)	0,818 (0,817)	0,057	14,47	***
$H_{1b}$	Environmental Concern (EC)	→	Subjective norms (SN)	0,392 (0,430)	0,058	6,802	***
$H_{1c}$	Environmental Concern (EC)	→	Perceived behavioral control (PB)	0,206 (0,251)	0,054	3,825	***
$H_{2a}$	Attitude (AT)	→	Separation Intention (SI)	0,387 (0,428)	0,058	6,668	***
$H_{2b}$	Subjective norms (S.N.)	→	Separation Intention (SI)	0,290 (0,292)	0,055	5,280	***
$H_{2c}$	Perceived behavioral control (PB)	→	Separation Intention (SI)	0,107 (0,101)	0,056	1,909	0,049
$H_3$	Facilities (FC)	→	Separation Intention (SI)	0,089 (0,127)	0,039	2,258	0,024
$H_4$	Time Pressure (TP)	→	Separation Intention (SI)	0,192 (0,190)	0,055	3,514	***

Source: Authors' calculation.

Note: In parentheses, the normalized regression weights are shown; \*\*\* P < 0,01.

3.1.4. Testing the Research Hypothesis

The combined results in Table 5 show that environmental concerns positively impact attitude, subjective standards, and behavioral control. Thus, hypotheses H1a, H1b, and H1c are accepted. Attitudes,

subjective standards, and behavioral control affect the intention to classify plastic waste. Thus, hypotheses H2a, H2b, and H2c are accepted. Facilities positively impact the intention to sort plastic waste; Hypothesis H3 is accepted. Time pressure positively impacts the intention to sort plastic



waste; Hypothesis H4 is not accepted. The theoretical relationships in the research model are statistically significant at the 5% level.

## 4.2. Discuss the Results

Research results show that attitudes, subjective standards, behavioral control, and facilities affect people's intention to classify plastic waste. Time pressure tends to affect the research hypothesis. Environmental concerns greatly influence people's attitudes (normalized regression weight = 0.817). People's environmental concerns also strongly influence subjective norms (normalized regression weight = 0.430). The extent to which people control their behavior depends largely on their environmental concerns. Environmental concerns have a relatively weaker effect on people's degree of behavioral control (normalized regression weight = 0.251). According to the theory of planned behavior, if people think they can perform a particular behavior, they are more willing to do it. This is known as behavioral control, which was found to be significantly associated with behavioral intention.

The mediating effects also indicate that environmental concerns indirectly affect the intention to sort plastic waste through the TPB model, i.e. attitude, subjective norm, and behavioral control mediated conveys the effect of people's environmental concerns on the intention to sort plastic waste. This result is consistent with the study of I. Ajzen and Fishbein (1977). Chu and Chiu (2003) demonstrated that people who recycle household waste believe that their actions benefit the environment; therefore, they tend to pay more attention to environmental issues.

Environmental actions can only be taken with the proper infrastructure (nearby recycling facilities, convenient waste collection services, etc.). Lack of infrastructure is one trouble. The provision of facilities to promote waste segregation will only be effective when facilities are tailored to individual requirements (Lorenz et al., 2017). Time pressure was also found to be a significant predictor of plastic waste segregation intentions; However, the results of this study are not consistent with previous studies.

## 5. Conclusion

Perceptions of the negative environmental impact of plastic waste are shaped by a complex process involving academic, economic, and social factors. This study aims to analyze the factors affecting the intention to classify people's plastic waste in the Ho Chi Minh city. The study results show that raising people's environmental awareness is very important. Once people care about environmental issues, they will have a positive attitude and behavior

towards sorting plastic waste. From a macro perspective, relevant agencies need to realize the things that have been legalized in real life and strengthen the training of responsible personnel in environmental pollution management, strictly manage plastic waste treatment processes, monitor, detect and warn early of harmful risks to the environment and should support waste collection and treatment facilities fully. From a micro perspective, schools need to add extra-curricular activities to provide people with knowledge about sorting plastic waste, the harmful effects of plastic utensils, and organizing programs and contests to learn about the environment, encourage the establishment of clubs, organize environmental projects to attract people who have concerns about the environment but have insufficient knowledge.

This article has some limitations. Firstly, because our sample is limited to HCMC residents, the study results are not representative of the entire population of Vietnam. Second, this paper is based on cross-sectional data, which is not the best way to establish a causal relationship between the intention to sort plastic waste and its drivers. Future studies that need to be based on a nationally representative sample from panel data can address these limitations.

## References

- Ambrin, S., Muhammad, H., Muhammad, A., Syed, A. G., (2018). Determination the Level of Knowledge, Attitude, and Practices Regarding Household Waste Disposal among People in Rural Community of Lahore. *International Journal of Social Sciences and Management*, 5(3), 219-224.
- Ajzen, I., & Fishbein, M. (1977). Attitude-behavior relations: A theoretical analysis and review of empirical research. *Psychological Bulletin*, 84(5), 881- 888.
- Ajzen, I. (2011). The theory of planned behaviour: Reactions and reflections. *Psychology and Health*. 26(9), 1113–112
- An, L., Liu, Q., Deng, Y., Wu, W., Gao, Y., & Ling, W. (2020). Sources of microplastic in the environment. *The Handbook of Environmental Chemistry*, 90, 143-159. Springer.
- Chow, C.-F., So, W.-M. , Cheung, T.-Y., & Yeung, S.-K. (2017). Plastic waste problem and education for plastic waste management. *In Emerging practices in scholarship of learning and teaching in a digital era* (pp. 125-140): Springer.
- Chu, P. Y., & Chiu. (2003). Factors influencing household waste recycling behavior: Test of an integrated model 1. *Journal of Applied Social Psychology*. 33(3), 604-626.
- Diamantopoulos, A., Schlegelmilch, B. B., Sinkovics, R. R., & Bohlen, G. (2003). Can socio-demographics still play a role in profiling green consumers? A review of the evidence and an empirical investigation. *Journal of Business Research*. 56(6), 465-480.
- Fan, B., Yang, W., & Shen, X. (2018). A comparison study of "motivation-intention-behavior" model on household solid waste sorting in China and Singapore. *Journal of Cleaner Production*. 211(2019), 442-454.

- Fryxell, G. E., & Lo, C. (2003). The influence of environmental knowledge and values on managerial behaviours on behalf of the environment: An empirical examination of managers in China. *Journal of Business Ethics*, 46(1), 45-69.
- Galati, A., Sabatino, L., Prinzivalli, C. S., D'Anna, F., & Scalenghe, R. (2020). Strawberry fields forever: That is, how many grams of plastics are used to grow a strawberry? *Journal of Environmental Management*, 276, 111313.
- Gill, J. D., Crosby, L. A., & Taylor, J. (1986). Ecological concern, attitudes, and social norms in voting behavior. *Public Opinion Quarterly*, 50(4), 537-554.
- Guerrero, L. A., Maas, G., & Hogland, W. (2013). Solid waste management challenges for cities in developing countries. *International Journal of Integrated Waste Management*, 33(1), 220-232.
- Hudek, I., Tominc, P., & Širec, K. (2021). The impact of social and cultural norms, government programs and digitalization as entrepreneurial environment factors on job and career satisfaction of freelancers. *Sustainability*, 13(2), 779.
- Jalil, M. A., Mian, M. N., Rahman, M. K. (2013). Using plastic bags and its damaging impact on environment and agriculture: An alternative proposal. *International Journal of Learning and Development*, 3(4), 1-14.
- Kelly, W. (2002). Harnessing the river of time: A theoretical framework of time use efficiency with suggestions for counselors. *Journal of Employment Counseling*, 39(1), 12-21.
- Kim, K., Uysal, M., & Sirgy, M. (2013). How does tourism in a community impact the quality of life of community residents? *Tourism management*, 36 (2016), 527-540.
- Kim, Y. J., Njite, D., & Hancer, M. (2013). Anticipated emotion in consumers' intentions to select eco-friendly restaurants: Augmenting the theory of planned behavior. *International journal of hospitality management*, 34(3), 255-262.
- Klemeš, J. J., Van Fan, Y., Tan, R., Jiang, P. (2020). Minimising the present and future plastic waste, energy and environmental footprints related to COVID-19. *Renewable and Sustainable*, 127(2020), 109883.
- Knickmeyer, D. (2020). Social factors influencing household waste separation: A literature review on good practices to improve the recycling performance of urban areas. *Journal of cleaner production*, 245(2020), 118605.
- Leao, S., Bishop, I., & Evans, D. (2001). Assessing the demand of solid waste disposal in urban region by urban dynamics modelling in a GIS environment. *Resources, conservation and recycling*, 33(4), 289-313.
- Lejuez, C. W., Hopko, D. R., & Hopko, S. (2001). A brief behavioral activation treatment for depression: Treatment manual. *Behavior modification*, 25(2), 255-286.
- Lobb, E. A., Kristjanson, L. J., Aoun, S., Monterosso, L., Halkett, G. K., & Davies, A. (2010). Predictors of complicated grief: A systematic review of empirical studies. *Death studies*, 34(8), 673-698.
- Luo, H., Zhao, L., & Zhang, Z. (2020). The impacts of social interaction-based factors on household waste-related behaviors. *Waste Management*, 118, 270-280.
- Lozano, M., & Vallés, J. (2007). An analysis of the implementation of an environmental management system in a local public administration. *Journal of environmental management*, 82(4), 495-511.
- Matiuk, Y., & Liobikienė, G. (2021). The impact of informational, social, convenience and financial tools on waste sorting behavior: Assumptions and reflections of the real situation. *Journal of Environmental Management*, 297, 113323.
- Negash, Y, Sarmiento, L., Tseng, M.-L., Lim, M., & Ali, M. H. (2021). Engagement factors for household waste sorting in Ecuador: Improving perceived convenience and environmental attitudes enhances waste sorting capacity. *Resources, Conservation and Recycling*, 175, 105893.
- Nguyen, B. T., Do, D. D., Nguyen, T. X., Nguyen, V. N., Nguyen, D. T. P., Nguyen, M. H., & Bach, Q.-V. (2020). Seasonal, spatial variation, and pollution sources of heavy metals in the sediment of the Saigon River, Vietnam. *Environmental Pollution*, 256, 113412.
- Omran, A., Gavrilesco, M. (2008). Municipal Solid Waste Management In Developing Countries: A Perspective On Vietnam. *Environmental Engineering & Management Journal*, 7(4), 469-478.
- Ossama, L., Latifah, M., Amir H. S, and Siti. S. M. (2021). Moderating Effects on Residents' Willingness in Waste Sorting to Improve Waste Handling in Dammam City, Saudi Arabia. *Recycling*, 6(2), 24-37.
- Roche Cerasi, I., Sánchez, F. V., Gallardo, I., Górriz, M. Á., Torrijos, P., Aliaga, C., & Franco, J. (2021). Household plastic waste habits and attitudes: A pilot study in the city of Valencia. *Waste Management & Research: The Journal for a Sustainable Circular Economy*, 39(5), 679-689.
- Santoso, A. N., & Farizal. (2019). Community Participation in Household Waste Management: An Exploratory Study in Indonesia. *E3S Web of Conferences*, 125, 07013.
- Shen, J., Zheng, D., Zhang, X., & Qu, M. (2020). Investigating Rural Domestic Waste Sorting Intentions Based on an Integrative Framework of Planned Behavior Theory and Normative Activation Models: Evidence from Guanzhong Basin, China. *International Journal of Environmental Research and Public Health*, 17(13), 4887.
- Sreekumar, P., Thomas, S. P., marc Saiter, J., Joseph, K., Unnikrishnan, G., & Thomas, S. (2009). Effect of fiber surface modification on the mechanical and water absorption characteristics of sisal/polyester composites fabricated by resin transfer molding. *40(11)*, 1777-1784.
- Stern, D. I., Common, M. S., & Barbier, E. (1996). Economic growth and environmental degradation: the environmental Kuznets curve and sustainable development. *World development*, 24(7), 1151-1160.
- Tali Tal, R. (2004). Community-based environmental education— a case study of teacher–parent collaboration. *Environmental Education Research*, 10(4), 523-543.
- Taylor, S., & Todd, P. (1995). An Integrated Model of Waste Management Behavior. *Environment and Behavior*, 27(5), 603-630.
- Wang, C., Chu, Z., & Gu, W. (2021). Participate or not: Impact of information intervention on residents' willingness of sorting municipal solid waste. *Journal of Cleaner Production*, 31(8), 128591.
- Wang, H., Li, J., Mangmeechai, A., & Su, J. (2021). Linking Perceived Policy Effectiveness and Proenvironmental Behavior: The Influence of Attitude, Implementation Intention,

- and Knowledge. *International Journal of Environmental Research and Public Health*, 18(6), 2910.
- Xia, Z., Zhang, S., Tian, X., & Liu, Y. (2021). Understanding waste sorting behavior and key influencing factors through internet of things: Evidence from college student community. *Resources, Conservation and Recycling*, 17(4), 105775.
- Zhang, B., Lai, K., Wang, B., & Wang, Z. (2019). From intention to action: How do personal attitudes, facilities accessibility, and government stimulus matter for household waste sorting? *Journal of Environmental Management*, 23(3), 447–458.