

Creep Characteristics of Rocks and Concrete - A Comparison

암(岩)과 콘크리트의 Creep 특성에 대한 비교평가



김학문*
Kim, Hak-Moon

Abstract

It is well known fact that all rocks exhibit brittle properties and time depends strain properties(creep). An understanding of the time dependent deformation behaviour of rocks is believed to be essential in the field of Civil and tunnelling. The rock and concrete creep in various forms of loading conditions and physical environment are reviewed. A comparison of creep behaviour between rocks and concrete is provided, in order to bring two existing relatively independent methods of predicting creep strain closer together. It was felt that the physical process in the creep of rocks would be similar to the process in creep of concrete. Since experiments and observations have shown that non-elastic(creep) mechanical behaviour of all crystalline solids (i.e. concrete, rocks, ceramics and refractories) and single materials have a common base. Also a comparison of the results for the accepted methods of estimating creep in rocks and concrete under - multiaxial loading was attempted to extend the knowledge of deformational characteristics of these two materials.

Keywords : Rock Creep, Concrete Creep, Creep Strain, Test Method, Physical environment, Comparison.

* Professor Dept of Civil Engineering, Dankook University

요 지

모든 암석들이 취성이나 시간변형거동인 Creep 특성을 나타낸다는 것은 잘 알려진 사실이다. 암석들에 대한 시간변형거동의 이해는 토목이나 터널기술분야에 필수적인 요건이 된다. 그러므로 다양한 하중조건과 물리적 환경상태에서 암석과 콘크리트에 대한 Creep 특성을 조사하였다. 두가지 다른 Creep 변형예측공식을 사용하여 그 결과를 비교함으로써 이들 재료들의 유사점을 찾아보았다. Creep 변형 예측공식을 사용하여 3축압축 상태에서 얻어진 실험결과들과 비교 평가하였다.

주요어: 암의 Creep, 콘크리트의 Creep, Creep 변형, 실험방법, 물리적환경, 비교평가

1. Introduction

The time dependent deformation(creep) of rock like many other solid materials has drawn much attention over many years due to its unfavourable offset on material stability.

The creep phenomenon may be described as slow deformation over long periods of time when rock-like solid material is subjected to a stress. This slow deformation may be more or less continuous downward and outward movement which is essentially viscous under a constant compressive stress sufficient to provide permanent deformation.

The main problem associated with creep is that failure of rock and concrete structures may occur at well below the normal short-term strength.

This paper presents a review of rock creep in various forms of loading (bending, compression, tension etc.), the effects of the physical environment(Pressure of water, temperature, solutions, confinement etc.) and a comparison of those properties with concrete.

Creep testing equipment and measuring techniques in laboratory and field are introduced in order to help in understanding the evaluation of representative long-term strength of rocks in

practice.

The general creep behaviour of concrete was not very different from that of rock when considering the shape of the creep curve, although the process and the mechanisms were some what different. The multiaxial creep equation based on elastic theory was examined by the experimental creep results on gypsum and it was found that the equation provided 30% more creep strain than the measured value.

2. Brief Review of Rock and Concrete Creep

2.1 Creep Nature of Rock

The susceptibility of rock to creep varies widely from weak sedimentary rocks to strong igneous and metamorphic rock types. The most hazardous rock types are mudstones, shales, clay cemented sandstones, evaporites (i.e. gypsum, coal, potash, salt, alabaster, trona, etc.) in which the secondary creep can considerably exceed the elastic deformation.

The Time-strain pattern exhibited by rocks is

very similar to that presented by concrete and a wide range of materials(i.e. metals, ceramics, polymers, glass and many other mineral crystals).

A typical creep curve for rocks under constant stress and temperature is shown in Fig. 1. This curve consists of four different portions as described below :

- 1) The instantaneous elastic strain which occurs as soon as a load applied, represented by AB.
- 2) The primary creep : -A primary phase of strain at a decreasing rate. This phase of creep is also referred to as elastic creep, elastic flow, transient creep, delayed elastic deformation etc., represented by BC.
- 3) The secondary creep : -A period of steady state creep in which the rate of strain (slope of linear line) is a constant. The curve represented by the portion CD, namely, steady state creep, viscous creep, pseudo-viscous flow, plastic flow.
- 4) The tertiary creep : -A final phase of accelerating deformation during which the rock strength is rapidly lost and failure is initiated.

This part of the curve is represented by DE.

As shown in the typical creep curve of rocks, the primary appears in a relatively short time compared to the steady state of secondary creep. Except in some special cases, the secondary or steady creep has considerable importance in the study of creep behaviour and stability of rocks since it takes place over a long period of time.

Whereas, the tertiary creep strain has very little engineering value because of the final unpredictable sudden rupture behaviour. The tertiary

creep may only appear in a creep test at very high stress or high temperature or after many years of sustained load condition.

The creep phenomenon of rocks has many interrelated influential factors such as stress conditions, temperature, moisture shape and size effects, solutions, confinement and water pressure etc.

In order to describe the complexity of strain-time(creep) behaviour of rocks, many rheological models have been developed.

As explained in the previous section, the rock possesses brittle properties and time dependent properties.

In other words, elastic and plastic or viscous characteristics. An increase in plastic strain(i.e. creep) may follow a rheological model which can be represented by a coefficient of viscosity.

The typical creep curve of rock can be fitted in the combination of the rheological components of the visco-elastic and B-V model(Bingham Body and Voigt Unit).

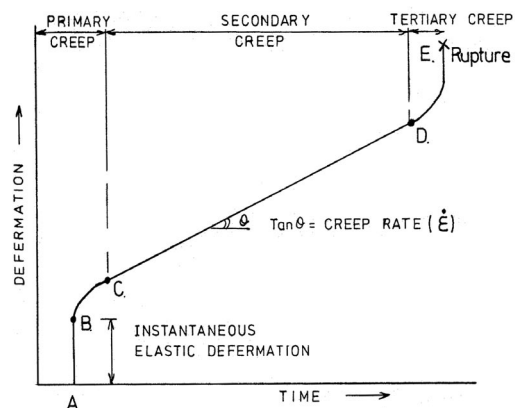

Fig. 1 Typical Creep Curve

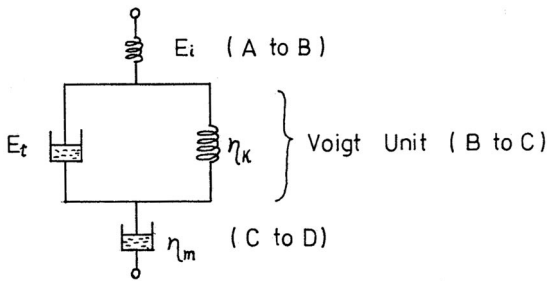

Fig. 2 Visco-Elastic Model

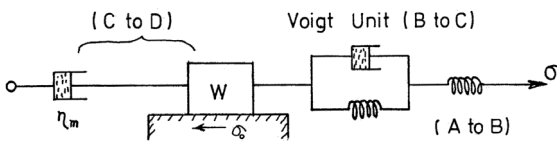

Fig. 3 Bingham-Voigt Model

The interpretation of the rheological models in Fig. 2 and Fig. 3 into typical creep curve of rock in Fig. 1 is described in the two model systems as follows :

- Visco-elastic model (Burger's Body or Maxwell-Voigt Unit)

The spring(E_i : elasticity modulus) represents the instantaneous elastic deformation(AB). The dashpot and spring sets, Voigt, Unit, identify the primary creep(BC).

The secondary creep(pseudo-viscous flow) is characterized by the dashpot(CD).

The tertiary creep is not included in this model study.

2.2 Measurement of Rock Creep in Laboratory

The methods of predicting creep strain in rocks

in-situ may be as difficult as obtaining results from the laboratory creep tests. The knowledge of correlation between the laboratory data and field measurement is considered to be of prime importance in the analysis of creep behaviour. The major problem associated with, laboratory tests is that the creep strain and long-term strength of rocks comprises many influential factors, such as loading conditions, temperature, moisture, sample shape and size, solutions, confinement, water pressure etc, Also considerable attention and time are required to produce meaningful creep results in laboratory.

Most previous investigators pointed out the following important requirements which are essential for creep apparatus design.

- 1) Any movement and deformation of apparatus with measuring devices must be negligible in order to maintain a constant applied stress over the whole period of tests.
- 2) The range of strains involved in the creep of rocks is relatively small, so sufficiently sensitive and stable measuring devices are required.
- 3) Automatic control facilities for the electrical systems and mechanical equipment are necessary to operate without any attention during weekends, holidays, etc.
- 4) Temperature and humidity should be maintained as nearly constant as possible during the creep test.

2.2.1 Triaxial Creep Tests

A triaxial compression creep apparatus for study

of creep behaviour on air dried gypsum and anhydrite rocks. The apparatus consists of three main parts(Fig. 4) :

1) Pressure Source and Control System,

Loading was applied by means of high ressure nitrogen gas for the axial and confining pressure. The automatic control of loading and accurate calibration to the apparatus was carried out by the control system

2) Pressure Cell

The size of pressure cell to provide ambient pressure was a hollow steelcylinder of internal

diameter 64mm and length of 228mm, which was big enough to accom–modate a specimen size of 76.2mm long and 25.4mm diameter.

3) Load and Displacement Measurement System.

The internal measurement of the axial load was monitored by the triaxial cell and an internal load cell. The axial strain and the lateral strains were measured by three linear variable differential transformers(LYDTS) and two strain gauges respectively. The strain variations were measured by using the strain gauge indicator peckel type T-200.

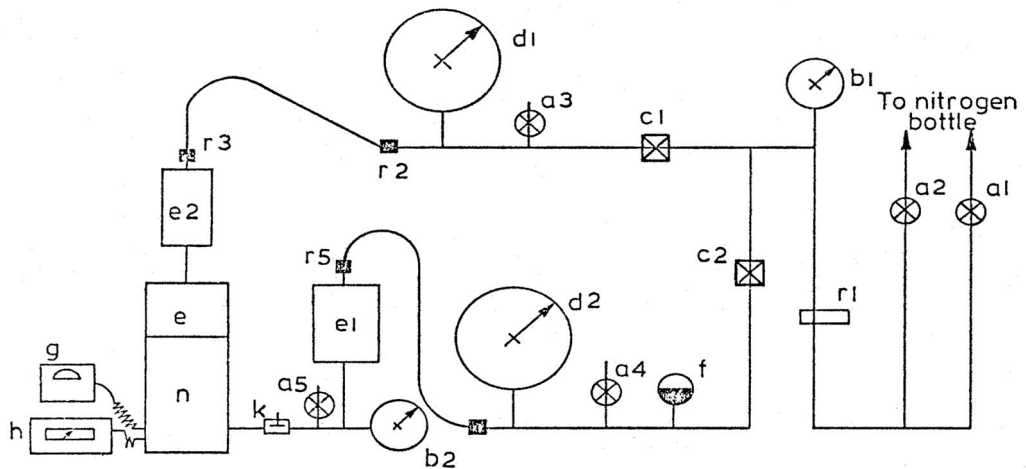

- a1, a2, 5 - Shut-off valve
- b1 - Nitrogen bottle pressure gauge
- b2 - Confining pressure gauge
- e2 - Axial load intensifier
- c1 - Axial pressure control valve
- c2 - Confining pressure control valve

- d1 - Axial pressure gauge
- d2 - Confining pressure intensifier
- e2 - Axial load intensifier
- e3 - Pressure cell head
- f - Automatic relief valve

- g - Strain gauge indicator
- h - transducer multimeter
- k - Oil inlet valve
- n - Pressure cell
- r1, r2, ,r5 - Filter

Fig. 4 Schematic Diagram of Triaxial Creep Apparatus

The specimens are tested under the following conditions.

Specimen size : 76mm long by 25mm diameter.

Axial pressure : tested to 135 N/mm²
(Max. capacity 400 N/mm²)

Confining pressure : Up to 50 N/mm²

2.3 Measurement of Concrete Creep

The strength of a concrete failing under sustained load involves several creep theories and complex time-strain creep curves. The most generally accepted theories, concerning concrete creep, supported by Demons⁶⁾(1974) and Neville²⁰⁾(1977) are the seepage and viscous shear theories. The seepage theory postulates that the movement of water is the prime cause of the creep which is reversible upon removal of load, whilst the viscous shear theory postulates that the irrecoverable creep is a pure shear process which modifies the movement of cement gel particles with to some extent, the aid of the interconnecting water layers of the gel.

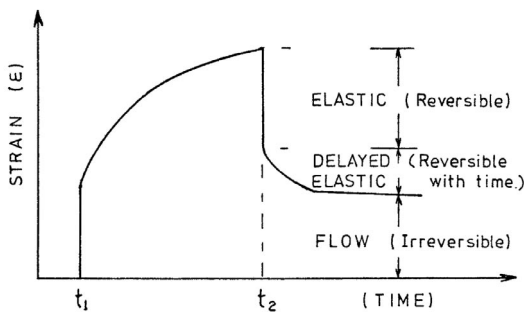

where t_1 : Time of load application.
 t_2 : Time of load removal.

Fig. 5 Typical strain-time curve for concrete under sustained load

The combination of these two theories has been a dominant explanation of creep in concrete, but the actual proportion of their strain contribution to the experimental data is not known upto now. The experimental creep strains measured by Illston¹¹⁾(1965) are expressed in terms of three main components : elastic, delayed elastic and flow, as defined in Fig. 5.

2.3.1 Mathematical Models and Their Mechanisms for Concrete

Various mathematical models have been suggested to represent the pattern of experimental creep curves of concrete.

The simplicity of the model can be arranged under the assumption that concrete consists of two parts :

Cementitious materials(Matrix) which creeps at low stresses due to viscous flow, and inert aggregate(Aggregate) which does not flow under load.

The following four mathematical models were proposed to select the representative type which traces the experimental creep curve best as shown in (Fig. 6).

Counto⁰⁾(1964) found that model 4, a central core representing the aggregate surrounded by a matrix

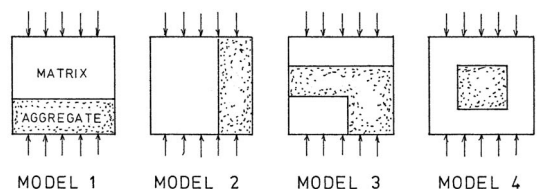

Fig. 6 Mathematical models for concrete

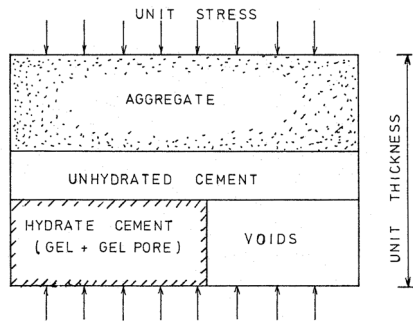

Fig. 7 The Gel compliance Factor composite models.

of cement paste, gives the most reliable estimated creep strain, close to the experimental results.

Ali and Kesler¹¹(1964) introduced “the gel compliance factor” which expresses the creep effects upon both the properties of aggregate and the degree of hydration of the cement gel.

Fig. 7 shows the gel compliance factor composite model which implies that the “specific creep” is function of water / cement ratio, maturity of concrete and volume concentration of aggregate.

Thomas²¹(1933) explained that when the concrete is loaded, the cement flow is resisted by the presence of aggregate, and as a result of this, the applied stress is gradually transferred from the cement paste to the aggregate.

Therefore, the rate of creep ($\dot{\epsilon}$ = slope of creep curve) is progressively reduced with time.

Neville²⁰(1970) concluded that the slow long-term part of creep is due to causes other than seepage, but the deformation can develop only in the presence of some evaporable water.

This type of mechanism implies that it is viscous flow or sliding between the gel particles which in turn creates irreversible long term creep.

3. Physical Environmental Effects on Rock Creep

The influential factors in creep behaviour in rocks have been studied by many investigators, and the details are discussed in chapter 2.

Misra¹⁷(1962) found that the creep behaviour of rocks is greatly affected by temperature and presence of solutions. The logarithmic relationship in creep curve gradually changed into power law “ $c t^n$ ” as temperature increased.

Increase in temperature considerably escalates the creep strain (ϵ) as well as creep rate ($\dot{\epsilon} = d\epsilon/dt$). He also reported that the effect of the pressure of water, dilute acetic and sodium chloride solution on all types of rocks except granodiorite, was to increase the creep rate significantly. The creep strain and rate ($\dot{\epsilon}$) decreased with increasing the confining pressure under constant axial stress.

Elizzi thinks the reason was the confining pressure may decrease the size, number and propagation of fractures during creep.

Murrell¹⁸(1962), Williams and Elizzi^{26, 27}(1976) reported that the modulus elasticity (E) increased linearly with increasing the confining pressure in both dry and saturated conditions. This statement was supported by Ali²¹(1979).

Ali conducted a creep study to find out the effects of specimen size in dry and saturated conditions. He reported the uniaxial compression and tension, bending strength reduced with increasing specimen size in all physical environmental conditions. This is in agreement with the experimental results represented by Gaddy, Evans and Pomeroy,

Skinner, Mogi, Bieniawski and Pratt et al.

3.1 Influence of Temperature

3.1.1 Creep Theories Influence of Temperature

The theoretical relationship between the absolute temperature and rate of creep strain(steady-state creep rate ($\dot{\epsilon}$)) has been established by Glasstone, Laidler and Eyring(1941) ($\dot{\epsilon} = d\epsilon/dt$)

$$\frac{d\epsilon/dt}{\epsilon_0} \propto \exp\left(\frac{Q}{KT}\right) \sinh\left(\frac{\sigma}{\sigma_0}\right) \quad (1)$$

Where Q : Activation energy,
 K : Boltzmann's constant,
 T : Absolute temperature,
 σ : Stress

Experimental results show that the rate of creep strain($\dot{\epsilon} = d\epsilon/dt$) depends on temperature(KT).

$$d\epsilon/dt \propto A \exp\left(-\frac{Q}{RT}\right) \quad (2)$$

(3-2) equation can be rewritten

$$d\epsilon/dt \propto A \exp\left(-\frac{Q}{KT}\right) \quad (3)$$

Where A : constant,
 R : the Gas constant.

The activation energy(Q) can be evaluated by the following equation (5).

The specific creep strain at times(t_1 and t_2) can be related to respective temperatures of T_1 and T_2 , when the equation (3) becomes :

$$t_1 \cdot A \cdot \exp\left(-\frac{Q}{RT_1}\right) = t_2 \cdot A \cdot \exp\left(-\frac{Q}{RT_2}\right) \quad (4)$$

$$\text{or } Q = \frac{R}{\log_e} \frac{T_1 T_2}{T_2 - T_1} (\log t_1 - \log t_2) \quad (5)$$

The effect of activation energy(Q) on creep behaviour indicates the amount of creep resistance within the material itself as well as the formation of internal structure.

This method is widely used for creep behaviour of metals at elevated temperature. Further investigation of this equation in conjunction with rock material seems to be necessary.

Mirsa suggested the following creep equations at various temperatures.

a) At low temperature

$$\epsilon = A \log t \quad (\text{For low value of } t).$$

$$\epsilon = B t^m \quad (\text{For high value of } t).$$

b) At high temperature

$$\epsilon = B t^m \quad (\text{For lower value of } t).$$

$$\epsilon = C t^n \quad (\text{For higher value of } t).$$

The values of term "C tⁿ" were smaller than the term "B t^m" indicating creep curve diminishing asymptotically.

c) A further increase in temperature (about of melting point) the constant value "n" increased gradually to become $n \geq 1 > m$.

3.1.2 Experimental Results

An extensive creep study on various rocks (Darley-Dale sandstone, anhydrite, dolo-mite, marble and olivine) at elevated temperature was carried out by Misra¹⁷⁾(1962).

All the experimental results were fitted into one of the logarithmic relationships either ($\epsilon = A + B \log$

Table 1. Creep Equations for Marble at various temperatures.

Temperature	Equation	$\epsilon = A + B \log t$ or $\epsilon = C t^n$
300 c°		$\epsilon = (3.89 + 40.72 \log t) 10^{-6}$
400 c°		$\epsilon = (44.5 + 50.26 \log t) 10^{-6}$ (t ≤ 100mins)
		$\epsilon = 42.0 t^{0.25} \times 10^{-6}$ (t > 100mins)
500 c°		$\epsilon = 0.31 t^{0.25} \times 10^{-3}$ (t ≤ 100mins)
		$\epsilon = 0.65 t^{0.15} \times 10^{-3}$ (t > 100mins)
600 c°		$\epsilon = 0.288 t^{0.82}$ (t ≤ 100mins)
		$\epsilon = 0.15 t^{0.22}$ (t > 100mins)

t) or power law($\epsilon = c t^n$). The constants A, B, C and n in the above creep equation are evaluated by plotting creep strain(ϵ) versus log times(semi log graph) for “A” and “B” in the logarithmic law, and log creep strain(log ϵ) vs. log time(log t) graph for “C” and “n” in the power law. Also a least squares method can be used for the same purpose as explained by graphical method above.

3.2 Effects of Water and Other Solutions

Griggs⁸⁾(1936, 1939, 1940) conducted creep tests on alabaster immersed in water. He suggested the following formula to represent the steady-state rate($\dot{\epsilon} = d\epsilon/dt$).

$$d\epsilon/dt = a \cdot \sinh b (\sigma - s) \tag{6}$$

Where a, b and s are constants. According to the Maxwell Model,

$$d\epsilon/dt = \frac{\sigma}{3\eta} \text{ or } \eta(\text{Viscosity}) = \frac{\sigma}{3d\epsilon/dt}$$

$$\text{and } d(d\epsilon/dt)/d\sigma = \frac{1}{3\eta} = \text{constant} \tag{7}$$

(Secondary creep)

For the immersed alabaster :

$$d\epsilon/d\sigma = ab \cdot \cosh b (\sigma - s) \tag{8}$$

Griggs observed secondary creep when the specimens are immersed in water and the creep curve followed power law = $c t^n$.

Ali²⁾(1979) found that the presence of water on gypsum changes the creep behaviour from logarithmic relationship = $B \log t$, to power law even at low stresses. Many investigations on the role of water in creep behaviour have been carried out, but none of these attempted to evaluate the relationship between the creep strain and water. The difficulty seems to be that the creep phenomenon in water involves many different physical and chemical mechanisms which result in the capability of changing the structure, possible recrystallisation and various stress redistributions within cemented material and the solid inert materials.

3.2.1 Experimental Results

Griggs⁸⁾(1939, 1940) reported saturated rocks deformed an appreciable amount at small changes in stress. He observed that the creep rate($\dot{\epsilon}$)

Table 2. Short – term Compressive Strength in presence of solutions.

Rock Types	Dry Strength (1bs/SQ.in)	Saturated Strength / DryStrength × 100			
		in water	in Acetic Acid	in Sodium Carbonate	in Benzene
Anhydrite	15,000	77%	54%	77%	100%
Calarious Sandstone	14,500	72%	72%	79%	83%
Darley-Dale Sandstome	8,500	59%	59%	59%	100%
Dolomite	18,500	87%	65%	-	100%
Granodiorite	55,500	100%	100%	100%	100%
Marble	16,000	88%	56%	-	100%

exhibited by alabaster in water, was 25 times greater than that in the dry condition. He thinks that this effect was caused by recrystallisation.

Wawersik found the creep rate of westerly granite and sandstone increased by a ratio of two in immersed conditions.

Misra¹⁷(1962) carried out extensive creep tests on anhydrite, beer stone, calcareous sandstone, Darley-Dale sandstone, granodiorite, marble and pennant sandstone immersed in water and other solutions. He obtained the following experimental results for various rocks.

The effect of water and acetic acid on anhydrite and marble are significant by decreasing 50% of their instantaneous strength. One of these reasons was that both anhydrite and marble contain highly soluble minerals such as calcium sulphate and calcite (calcium Carbonate) respectively.

Whereas granodiorite was not effected by any solutions or water.

3.3 Specimen Shape and Size Effects

Sangha²⁰(1972) studied the specimen slenderness

ratio (L/D) effect on sandstone and concrete, and found that the slenderness ratio of 2.5 provided most satisfactory results to minimise effects of ends restraints and releasing of strain energy after strength failure.

Ali²⁰(1979) conducted an investigation on the effects of specimen size under uniaxial compression, uniaxial tension and bending tests on both dry and saturated gypsum. He reported the following experimental results.

- 1) Uniaxial compressive strength is reduced by about 20% in both dry and saturated conditions with increasing size from 25.4 mm dia. to 50.8 mm dia.
Constant slenderness ratio(L/ D) of 3 was used throughout the tests.
- 2) Uniaxial tensile strength reduced by about 43% in dry and 28% in saturated conditions with increasing specimen size from 25.4 mm dia. to 50.8 mm dia.
Constant slenderness ratio (L/D) of 3 was used throughout the tests.
- 3) Bending tests on specimen size 240 mm long 40 mm wide with varying thickness from 15mm to

28mm(four types) were carried out using four point loading in dry and saturated conditions. The reduction of strength found was in order of 8% for dry case and 9% in the case of saturated specimens.

As pointed out by the previous investigators, it is clear that all rocks exhibit considerable reduction in strength with increasing size of specimens under any environmental conditions. This reduction seems to be obvious as the larger size of specimens are more likely to contain a gross weakness than a small one.

3.4 Effect of Confinement

Confining pressure affects the creep behaviour of rocks significantly under constant compressive stress, although high confining pressure(high compared with σ_u) are unlikely to be met with in civil engineering works.

Elizzi⁷⁾(1976) reported that the creep strain decreases with the confinement under a sustained compressive load. The rate of the creep by varying the confining pressure at constant differential stress increases linearly with confining Pressure, whereas above 74% σ_u on gypsum specimen the curve starts to take a parabolic shape concave upwards.

“Increasing the confining pressure on any rock changes some of its mechanical properties, it makes the rock more ductile than its nature at atmospheric pressure, it makes the rock deform under suitable axial load, plastically rather than in a brittle manner.”Murrell.

The confining pressure may decrease the size, number and propagation of fracture during creep, therefore and increase of the modulus of elasticity in both environmental conditions dry and saturated.

4. Major Influencing Factors of Creep Behaviour in Concrete

It has long been recognised that several additive mechanisms in concrete creep severely hampered an understanding of the relationship between the mechanical properties of multi-phase composite materials and the physical response of the material itself.

Knowledge of the constituents of concrete and their behaviour is very important to the understanding of the nature of creep strain at various phases under a sustained load.

The main constituents of concrete influencing the magnitude of creep strain are aggregate and cement paste.

The structure of hardened cement paste consists of unreacted cement, cement gel, crystalline hydration products, gel pore water, surface absorbed water, water vapour and capillary water.

Furthermore, the two environmental factors (temperature and humidity), maturity of concrete(degree of hydration), applied stress conditions (uniaxial or multiaxial stress) and age at loading will be discussed in this section.

4.1 The Relative Volume Ratio of the Aggregate to Cement Paste

The cement paste which comprises grains of hydrated cement paste(chemical reaction between water and cement)plays the supreme role in time-dependent deformation of concrete, whereas the presence of aggregate helps to resist the movement of the paste.

It is clear that creep strain in the cement paste under a sustained load increases with time, whilst the restraining effect of aggregate particles reduces the creep strain gradually, therefore the apparent elasticity of the paste decreases with time.

An experimental result shows that increase in aggregate volume from 60 to 75% (from 1 : 1 : 2 mix to 1 : 1 : 4 mix of concrete) reduced creep strain by as much as 50%.

The stiffness of aggregate is usually about 10 to 20 times greater than that of cement paste.

4.2 The Stiffness Effect of Aggregate

The effect of the mechanical and physical properties of aggregate upon the creep of concrete is also an important aspect of creep study inconjunction with shrinkage and creep of the aggregate itself, grading, size and shape, bond, elasticity, porosity and mineralogical content etc.

Generally aggregates exhibit negligible amounts of shrinkage strain expect aggre-gates containing high percentages of clay minerals which are normally avoid.

Counto⁴(1964) reported that as a result of the restraint which the aggregate exercises on the creep of cement paste, the sustained load is gradually transferred from the paste to the aggregate.

The stiffer the aggregate, the lower the residual stress on the current paste.

This means that the higher the elasticity modulus of the aggregate, the lower the amount of creep strain of concrete.

Troxell and davis³(1956) suggested that creep strain can be minimized by using well graded and the largest possible size of aggregate under satisfactory conditions of compaction.

But, this statement is unclear regarding the behaviour of creep mechanism associated with the constituents of concrete.

It can be said that an improvement of concrete strength may have indirectly reduced the creep strain.

Experimental results have indicated that the most susceptible aggregate to the concrete creep found to be in the order sandstone, basalt, gravel, granite, quartz and limestone.

The creep of aggregate plays a significant role in concrete deformation at very high stress and long-term loading.

The effect of aggregate stiffness upon concrete creep is shown in (Fig. 8) and indicates that there is

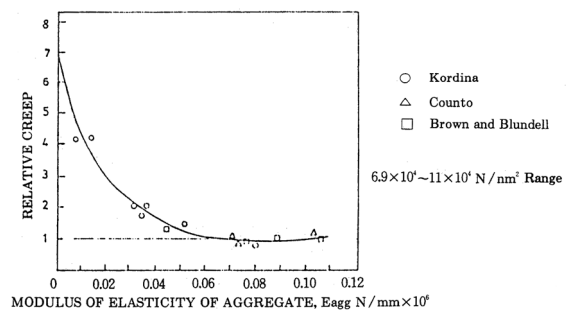

Fig. 8 Moulus of Elasticity of Aggregate, E_{agg} N/mm X 10^6

almost no change in creep strain at the modulus of elasticity($E_{agg.}$) values between $E_{agg} = 6,9 \times 10^4$ N/mm² and $E_{agg} = 11 \times 10^4$ N/mm²

4.3 Type of Cement

The type of cement used has direct influence on the formation of hydrated cement paste which is considered to be the major creep prone material in concrete. For a given age at loading, the creep is in the order of increasing magnitude with type of following cements : Aluminous, rapid-hardening, ordinary portland, portland blast-furnace, low-heat and finally maximum creep value in case of portland / pozzo-lan mixture.

4.4 Water / Cement Ratio

It is evident that creep increases with an increase in the water / cement ratio.

The increase in creep at high values of water / cement ratio is accompanied by an increase in cracks and shrinkage, consequently reducing the strength of the concrete.

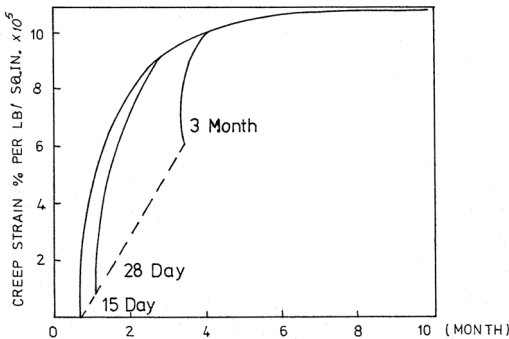

Fig. 9 variation in creep with age of concrete at loading

Lorman¹⁶⁾(1940) mentioned that the creep increased rapidly with an increase in the water/cement ratio for a limited range of mixes, but was unaffected by the amount of free or absorbed water.

Wagner²⁹⁾(1958) reported that creep strain increased linearly with water / cement ratios from 0.4 to 0.65(Generally used in practice).

4.5 Age of Concrete at Loading

Davis et a⁵⁾(1934) found that the rate of creep during the first few weeks under sustained load is much greater for concrete loaded at an early age than for older concretes.

This statement was supported by Glanville⁹⁾(1933) who noted that the creep rate at a later age(after a month) is independent of the age at loading, and this continued to the concrete of age 7years, during which creep was slow and decreasing.

(Fig. 9) shown the variation in creep with age of concrete at loading.

It can be seen that the creep for about the first month after applying the load governed by the age of loading decreasing with increasing age, and in the later stage rate of creep($\dot{\epsilon}$) depend on the actual age of concrete at the time of consideration.

Neville¹⁹⁾ (1960) introduced the following simple formula concerning creep and strength of concrete on loading which also changes with time.

$$\text{creep} \propto \frac{1}{\text{The strength of the concrete on loading}}$$

4.6 The Effect of Relative Humidity

This effect is regarded as one of the most important factors responsible for variations on concrete creep in practice.

The lower the relative humidity, the greater the creep strain under a sustained load.

The relative humidity has a direct influence over drying creep and the seepage of moisture from the concrete.

Troxell et al²⁵⁾ obtained the following creep strains in millions from the concrete specimens loaded under various conditions for 23 years.

In water	: -360 millions
In fog	: -380 millions
In Air, 70% of reliable humidity	: -800 millions
In Air, 50% of reliable humidity	: -1080 millions

In practice, drying of concrete may not be severe specially in U.K, where the average annual relative humidity is 80% and exposed members are liable to get wet by rainfall.

4.7 Temperature Effects

The temperature effect is the second most important environmental factor to the humidity since the majority of structures are operated with range of temperatures.

The promotion of water mobility in the concrete due to increasing temperature will increase creep strain.

The previous investigations indicated that creep

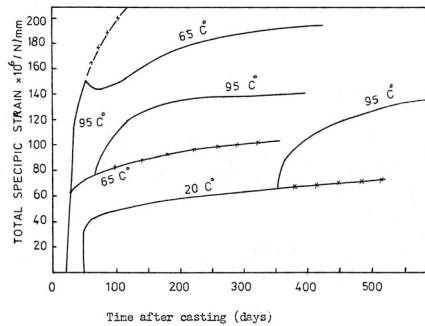

Fig. 10 variation in creep with age of concrete at loading

increases with temperature and is approximately proportional to it over a wide range, at least 0 ° to 100 °.

Also an increase in temperature reduces the modulus of elasticity of concrete.

Ruetz²²⁾(1965) noted that the 6day creep of dry concrete was considerably less than that obtained from concrete tested in a moist condition. However, temperature ranges between 40 ° to 80 ° had very little effect upon the creep of moist concrete, whereas the creep in the dry concrete was more than doubled over the same temperature range.

(Fig. 10) shows the effect of temperature variation upon creep of concrete, while subjected to sustained load.

The creep mechanism associated with high temperature is presented by Hansen who assumed that the viscosity of cement paste can be ascribed to viscous deformation in the boundary layers between the main inert(solid) particles.

The diffusion rate(creep rate) of molecules increases very rapidly with temperature.

$$\log \eta \propto \frac{1}{T} \quad \begin{array}{l} \eta = \text{coefficient of viscous shear.} \\ T = \text{absolute temperature.} \end{array}$$

Table 3. Influence of Size of Specimen on Creep and Shrinkage

Minimum Thickness	Correction factor for Creep and Shrinkage	Minimum Thickness	Correction factor for Creep and Shrinkage
< 5(mm)	1.6	40(mm)	0.8
5	1.5	60	0.7
10	1.15	80	0.55
20	1.00	100	0.5
30	0.9	> 100 and sealed 0.4 concrete	

4.8 Size of Concrete Member (or Specimen)

Several investigators have revealed that the size of concrete specimen showed a remarkable influence on creep and shrinkage :

The measured creep decreases with an increase in the size of the specimen but it becomes negligible when the specimen thickness exceeds about 90 cm.

Obviously small members are likely to be more influenced by changes in temperature and relative humidity than large members which are generally subjected to a far slower movement of movement in the concrete mass.

Ulitskii(28)(1962) has developed a correction table on influence of size of specimen on creep and shrinkage(shown in <Table. 3>).

5. Prediction of Concrete Creep and Their Measurements

Concrete creep curves under sustained load exhibit very consistent patterns which can be fitted into mathematical equations so that long-term creep behaviour may be traced from short-term

laboratory tests. In this section, the shape of the creep curves representing the mathematical expression for concrete creep will be discussed in conjunction with their applicability.

At present, there are two broad ways of assessing the creep equations. A limiting value of creep with “definite time” and unlimited value increasing “indefinitely with time”.

“A limiting value of creep” can be represented by the exponential and hyperbolic expression. “The indefinite creep” can be represented by the power and logarithmic expressions. It must be realised that the constants in the creep equations have to be determined from the results of laboratory creep tests, also, the larger the creep test time, the better the prediction of long term creep strain.

5.1 The Logarithmic Law

General form of equation is

$$\varepsilon_c = A \log(1+t) \quad (9)$$

Where A : A constant,

t : Time under load,

When $E_c = \frac{\sigma}{\epsilon_c}$ is expressed in terms of unit strain

$$\frac{1}{E_c} = \frac{\epsilon_c}{\sigma} = \frac{\epsilon_0}{\sigma} + \frac{\epsilon}{\sigma} \quad (10)$$

Where ϵ_0 : Instantaneous elastic deformation,
 ϵ_t : Creep strain,
 E_c : Effective modulus of concrete.

The unit creep strain, ϵ_t / σ is function of the age at loading(K) and duration of loading(t). The total unit strain for elastic and creep strains becomes,

$$\frac{1}{E_c} = \frac{1}{E_0} + f(K)\log_e(1+t) \quad (11)$$

Where E_0 : the instantaneous modulus of elasticity(σ/ϵ_0).

$f(K)$ and E_0 are obtained from laboratory test results plotted on a total specific strain ($1/E_c$) against $\log(1+t)$ graph(semi log scal).

$F(K)$ represents the slope of the straight line on the above graph and $1/E_0$ is the total specific strain at one day

Typical values for various concretes are in the following ranges.

$$\begin{aligned} \epsilon_c &= 0.281 + 0.096\log_e(1+t) \text{ and} \\ \epsilon_c &= 0.156 + 0.025\log_e(1+t). \end{aligned}$$

The equation(11) was adopted by the U.S. Bureau of Reclamation, and shows a good agreement with experimental data for long-term creep. The U.S.

Bureau of Reclamation used this equation extensively for mass concrete structures at stress-strength ratios not exceeding 0.35.

The requirements for a suitable creep apparatus are more or less the same as those described in chapter 2.1.1 for rock creep tests. Comparison among concrete creep tests results is extremely difficult due to the variation of specimen preparation which is mainly function of type and size of aggregate, water / cement ratio, curing conditions (moisture and temperature), age at loading and size and shape of specimens.

It is believed that the above described variable factors have hampered the development of a general creep equation for concrete on the basis of experimental results.

In this chapter, some of the various concrete creep results available in compression, tension and triaxial tests will be reviewed and compared with each other.

The interpretation of experimental results and their application in actual design is introduced in conjunction with the national code of practice(CP 110) and the inter-national recommendation.

5.2 Uniaxial Compression Test

Illston^{11, 12)}(1965) conducted uniaxial compression creep tests by using the following two different concrete specimens under the various environmental conditions.

He divided the creep curve into three components shown in Fig. 5

- 1) Elastic strain : elastic strain depends on the

Table. 4 Illuston's concrete test specimens

Series	Specimen Size(mm)	W/c	A/C	Temperature	R.H	Mln. age of loading	Cube Strength
1	300×120 dia	0.53	6.5	60°F	90%	10days	32N/mm ²
2	450×90 dia	0.4	3.2	60°F	63%	7days	46N/mm ²

Where W/C = Water / cement ratio (by weight).

A/C = Aggregate / cement ratio (by weight).

R, H = Relative Humidity.

age of concrete and the magnitude of the applied stress.

- 2) Delayed elastic strain : creep strain-stress relationship is approximately proportional(linear) in the early stage and at stress levels below 50 per cent of strength.
- 3) Flow : the rate of flow decreases as the age of the concrete is increased, and is independent of any previous loading.

William & kim³⁰(1973) carried out laboratory compression creep tests to provide data for interpretation of measured strains by vibrating wire strain gauges installed in a concrete dam.

Two series of test programs with different concrete mixes were conducted by measuring load, longitudinal stain and temperature on cylindrical shaped specimens of size 6in. dia. × 12 in. height over a period of 600 days.

1st series case with class "G" mix specimen only.

- G1 loaded to 500 p.s.i. at 28 days.
- G2 loaded to 250 p.s.i. at 28 days.
- G3. loaded to 500 p.s.i. at 106 days.
- G4 loaded to 500 p.s.i. at 400 days.
- G5 loaded occasionally to 500 p.s.i.(E test).
- G6 unloaded control specimen

(shrinkage evaluation).

He found that the experimental results obtained from the two series of the test programs are well in agreement with the following mathematical creep equation, proposed by the U.S. Bureau of Reclamation.

The total unit strain for elastic and creep strains :

$$1/E_0 = 1/E_0 + f(K)\log_e(t+1) \quad (12)$$

The Summarized test results for class "G" mix Only to be used for the calculation of stress changes in the dam, is shown in the next page. (Table. 5)

The modification factors for the temperature range 16c° to 26c° averaged 8.4 MS/c and for the shrinkage strain changes after 28 days was found to be 0.075 M^s/day

Rusch²³(1960) reported uniaxial creep test results for concrete under various sustained loads applied at age 56 days. (Fig. 5-1) shows strains of concrete prisms under sustained compressive loads at various stress / strength (α) ratios. Stress loads less than unity ($\alpha = \sigma/\text{strength}$ at 56 days) form a family of curves which eventually lead to failure with time

Table. 5 Uniaxial concrete creep test roult

CLASS "G" MIX			Total Unit Strain MS/P.S.I
K	1/E ₀	(K)	1/E _c
Days	Units-Microstrains/p.s.i (1MS = × 10 ⁻³ mm)		
28	0.360	0.160	0.900
50	0.334	0.148	0.915
100	0.303	0.130	0.902
200	0.287	0.113	0.886
300	0.283	0.107	0.883
400	0.280	0.104	0.903
500	0.279	0.103	0.919
600	0.279	0.101	0.925

when the stress level (α) exceeds 75 percent of ultimate strength,

L' hermite¹⁵(1959) suggested that creep strain increases linearly(elastic manner) with stress upto 40% of the ultimate strength, the relationship becomes non-linear(plastic manner) at stress levels beyond 40% of the concrete strength. This 40% of ultimate concrete strength indicates the creep limit under which the concrete will never be subjected to failure at any period of time.

(Fig. 12), is redrawn from the (Fig. 11) in terms of concrete strain versus α = σ/strength at 56 days.

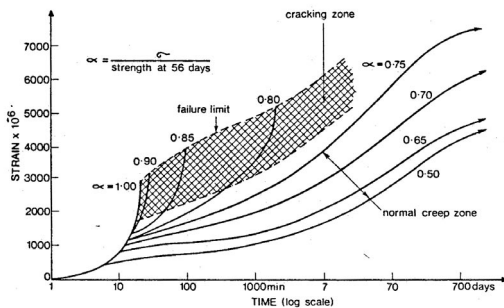

Fig. 11 Strains of concrete prisms under sustained compressive loads of varying stress / strength ratios

$$\alpha = \frac{\sigma}{\text{Strength at 56 days}}$$

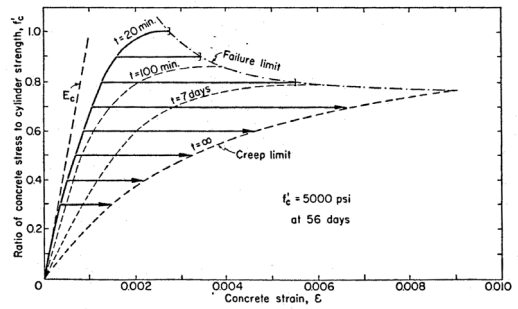

Fig. 12 Influence of load intensity and duration on concrete strain

This shows three important enclosing dotted lines which express all possible relationships between stress and strain.

- (1) E_c line : Short-term elasticity modulus representing straight elastic relationship.
- (2) Failure limit line : The sustained load causes failure at definite time.
- (3) Creep limit line : At stress levels below this line, the concrete will not be subjected to failure due to creep under sustained load for an indefinite duration.

5.3. Uniaxial Tensile Creep Test

It is not surprising that very limited tensile creep test results are available due to the experimental difficulties in the tensile testing of concrete and mainly the concept of concrete as a compressive material only. However, due to the growing importance of the tensile behaviour of concrete, this information has very much in demand in the field of water retaining structure design, the loss of prestress in concrete and possibility of cracking in the tensile zone of reinforced members etc.

The difficulties associated with the laboratory tests in tension are such that the applied stress is 10 to 20 times smaller than the testing stress in compression, and uniform tensile stress over the specimen may not be possible as the results of diff-

Illston^{11, 12)}(1965) investigated uniaxial tensile creep tests on concrete specimens by varying the stress level, time under load, age at loading and humidity of the storage environment. He reported the following remarks from the experimental results.

- 1) At stress levels above 50% of ultimate strength, the strain becomes a non-linear(plastic) relationship and below 50% of σ_u , the stress increases linearly(elastic) with stress.
- 2) The rate of creep diminishes asymptotically with increasing time.
- 3) Concrete in tension shows slow delayed elastic strain compared to the compression case.
- 4) The creep behaviour of concrete in tension is similar to that in compression. Domone⁶⁾(1974) carried out uniaxial tensile creep tests with concrete specimens having flared ends shown in (Fig. 13) . The strain was measured by means of 150mm vibrating-wire strain gauges embedded in the centre of the specimens.

The strength of concrete found for immerses

Max aggregate was 10mm		
Aggregate / cement ratio	5 (by weight)	6 various
Water / Cement ratio	0.5 (by weight)	mix were used.

specimens with W/C ratio of 0.5, 28 days strength were as follows.

Direct tension	2.14 N/mm ² .	test
cylinder-splitting(Brazilian test)	3.16 N/mm ² .	as per
Cube crushing	45.0 N/mm ² .	BS. 1881.

The size and flared end shape of concrete specimen in Fig. 13 reported to provide satisfactory results in tensile creep tests. Domone⁶⁾ concluded from the tensile creep test results that the stress-strain relationship continued to be proportional(elastic manner) upto 60% of ultimate strength for sealed concrete and 40% for the immersed curing case. The failure(fracture) line, found from the fracture envelope for 50 days duration creep tests, indicates that the long-term strength of sealed concrete is about 85% of the short-term strength, whilst about 75% for the immerses specimens. Therefore, the immersed concrete was about 10% stronger than the sealed one.

5.4 Triaxial Compression Creep Test

A few multiaxial creep tests have been reported with various shapes and sizes of concrete specimens. General equations have been developed

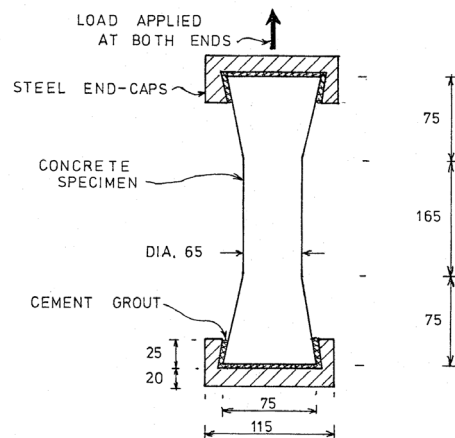

Fig. 13 Section through tensile specimen and end-caps.(Unit: mm)

to calculate the long-term multiaxial creep of concrete from the uniaxial creep tests by using the elastic value of Poisson's ratio.

Gopalakrishnan et al¹⁰⁾(1969) expressed the following remarks from the results of multiaxial creep tests.

- 1) Creep under multiaxial compression is less than at uniaxial compression of the same magnitude in the given directions. The axial creep of a specimen confined by lateral stresses is reduced by about 20% of its strain, compared with the uniaxial creep test case.
- 2) Uniaxial creep Poisson's ratio(CPR) is approximately the same as the elastic Poisson's ratio(EPR), about 0.17 to 0.20.
- 3) The creep strain-stress graph shows a linear relationship upto 47% of ultimate strength based on a cube strength about 60% based on a cylinder strength.
- 4) Creep in a simple multiaxially loaded member can be evaluated by using an equation similar to the elastic equation for anisotropic materials with creep Poisson's ratio(CPR) in any direction

$$\epsilon_1 = \epsilon_u / \sigma_u [\sigma_1 - \nu(\sigma_2 + \sigma_3)] \quad (13)$$

Where ϵ_1 = Net creep in direction σ_1 when the complex stress system acts.

ϵ_u = Uniaxial creep

σ_u = Stress in uniaxial compression.

ν = CPR under uniaxial compression.

ϵ_u / σ_u = Specific creep.

Table. 6 Williams & Kim³⁰⁾ creep test results

t=200 hours,		$\nu=0.27$
(a) $\sigma_1 = 46$	$\sigma_3 = 0$ gives	$\epsilon_{200} = 400$ MS (uniaxial).
(b) $\sigma_1 = 0$	$\sigma_3 = 30$ gives	$\epsilon_{200} = 150$ MS (uniaxial).
(c) $\sigma_1 = 46$	$\sigma_3 = 30$ gives	$\epsilon_{200} = 150$ MS (uniaxial).

MS = Microstrain

Author attempted to examine the equation(13) with experimental results on gypsum provided by Williams.

By applying Table. 6 to the equation(13).

$$\begin{aligned} \epsilon_1 &= \epsilon_u / \sigma_u [\sigma_1 - \nu(\sigma_2 + \sigma_3)] \\ &= 400/46 [46 - 0.27(30 + 30)] \\ &= 259 \text{ MS} > \text{(c) } \epsilon \text{ measured} = 200 \text{ MS.} \end{aligned}$$

The multiaxial creep strain measures in(C) case gives 30% less than the value calculated by equation(13). This discrepancy implies, by author's knowledge, the some modification factors may have to be applied to the equation(13) such as concrete mix factors, environmental curing conditions and specimen shape factors(i.e. cube strength or cylinder strength). Also systematic experimental creep tests on concrete in uniaxial and triaxial conditions on identical specimens is required to verify theoretical equations.

Illston and Jordan¹³⁾(1969) conducted concrete creep tests on cubical specimens under multiaxial compressive stresses.

The following mix of concrete was used.

Water / cement ratio = 0.4, Aggregate / cement ratio = 3.2max. aggregate size = 10 mm and blended ordinary Portland cement was used. differential shrinkage.

They presented the following results from the

experimental work.

- (1) The average values of elastic poisson's ratio were
 uniaxial stress case : 0.17
 biaxial stress case : 0.15
 triaxial stress case : 0.17

(2) A value of the creep poisson's ratio(CPR) equal to the elastic value(EPR) will give adequate results in engineering analysis.

Illston and Jordan¹⁸⁾(1972) suggested creep equations which enable us to predict the multiaxial creep strain from the creep control test(i.e. uniaxial creep test) and the creep poisson's ratio(CPR).

Their equations are based on the two components :

- a) Flow or irrecoverable creep(ϵ_f),
 b) Delayed elastic strain or recoverable creep(ϵ_d)

Both components are directly proportional to certain degrees to magnitude of stress.

The total creep strain during is

$$\delta\epsilon_{cl} = (\delta\epsilon_{f1} + \delta\epsilon_{d1}) - \nu_s [(\delta\epsilon_{f2} + \delta\epsilon_{d2}) + (\delta\epsilon_{f3} + \delta\epsilon_{d3})] \quad (14)$$

This may be rewritten by integrating with time to produce equation (15).

$$\epsilon_{cl} = \epsilon_1 - \nu(\epsilon_2 + \epsilon_3) \quad (15)$$

This equation was examined by using the experimental creep results shown in (Table. 6).

When

$$\begin{aligned} \nu &= 0.27 \\ \epsilon_{cl} &= \epsilon_1 - \nu(\epsilon_2 + \epsilon_3) \\ &= 400 - 0.27(150+150) \end{aligned}$$

$$= 319 \text{ MS} > \epsilon_{\text{measured}} = 200 \text{ MS.}$$

When $\nu = 0.5$;

$$\begin{aligned} \epsilon_{cl} &= 400 - 0.5(150 + 150) \\ &= 250 \text{ MS} > \epsilon_{\text{measured}} = 200 \text{ MS.} \end{aligned}$$

Although the material in this test was gypsum rather than concrete, it is clear that Illston's theoretical work should be applicable to any material. The maximum conceivable value of ν (Poisson's ratio) is 0.5(i.e. "hydrostatic" situation). Even if this value is used, we find $\epsilon_{cl} = 250 \text{ MS}$ which is still in excess of the measured value. Further investigation would be necessary to explain this wide discrepancy in creep strain between the Illston's equation(14) for concrete and the experimental creep results on gypsum in (Table. 6)

6. Conclusions

6.1 Behaviour and Measurement of Creep

- 1) The major factors influencing creep strain in rocks are loading condition, temperature, moisture, sample shape and size, representative samples(i.e homogeneous and isotropic specimens), solutions, confinement, water pressure etc.
- 2) Creep strain under multiaxial compression decreases with increasing confining pressure and hence increasing the apparent modulus of elasticity (E) linearly in both dry and saturated conditions.

- 3) The effect of the presence of water, dilute acetic and sodium chloride solution on most types of rock was to increase the creep rate significantly. It was also found that creep resistance reduces with increasing specimen size in all physical environmental conditions.
- 4) Misra(1962) reported that the magnitude of creep strain of Darley-Dale sandstone increased fourteen times as temperatures rose from 100c° to 600c° after one year at a stress level of 50% σ_u (ultimate strength).
- 5) Creep deformation in saturated rocks in between two and seven times greater than that in dry rocks. The changes in the reaction of saturated rocks to stress is dependent on the rate of water absorbed, which is function of mineral composition, chemical properties, porosity of rock etc.

6.2 Behaviour and Measurement of Creep in Concrete

- 1) Major influencing factors in concrete creep are known to be moisture content, temperature, shrinkage stress induced by drying, rate of hydration, aggregate characteristics, age at loading, size of concrete specimens, duration of loading etc.
- 2) The general creep behavior of not very different from that of rock when considering the shape of the creep curve although the process and the mechanisms may be somewhat different.
- 3) Concrete is liable to long-term failure, at stress levels estimated at a minimum 50% up to 75%

σ_u (ultimate strength) for the various time periods. This wide range of the stress levels may depend on the life of structure, age at loading, curing conditions (temperature and humidity), and constituents of concrete which affect the creep behavior.

- 4) The multiaxial creep equation based on elastic theory.

$$\epsilon_1 = \epsilon_u / \sigma_u [\sigma_1 - \nu(\sigma_2 + \sigma_3)]$$

was examined by experimental creep results on gypsum, and was found that this equation yields 30% more creep strain than the measured value.

This discrepancy implies, by author's knowledge, that some necessary modification factors may have to be applied to the equation regarding concrete mixes, environmental curing conditions, specimen shape factors(i.e. cube strength or cylinder strength). Also systematic experimental creep tests on concrete in uniaxial and triaxial conditions on identical specimens is required to verify theoretical equations.

- 5) Illstan's multiaxial creep equation was studied by using the same experimental creep results on gypsum already exercised in the above equation(16). The comparison of the Illstan's equation for concrete and the experimental creep result on gypsum was revealed that it is far from agreement.

Further investigation would be necessary to explain this wide discrepancy if the Illstan's theoretical work is applicable to any material.

REFERENCE

- 1) Ali, I. and Kesler, C., "Mechanisms of Creep in Concrete." Sym. on Creep of Concrete. Detroit, Amer. Conc. Inst., 1964. Publ. sp-9, pp. 35-57, paper No. 2.
- 2) Thomas F. G., "A Conception of the Creep of Unreinforced concrete and an Estimation of the Limiting Values." The Structural Engineer 11, no.2, 1993, pp. 69-73
- 3) Troxell, G.E. and Davis, H.E., 1961. "Composition and Properties of concrete." New York, McGraw-Hill Book Co., 1956, pp. 191-192.
- 4) Counto, Y.J., "The effect of the Elastic Modulus of the Aggregate on the Elastic Modulus, Creep and Creep Recovery of Concrete." Magazine of Conc. Research, Vol. 16, No. 43, Sept. 1964. pp. 129-138.
- 5) David, R.E, et al 1934. "Plastic Flow of Concrete under Sustained Stress." ASTM Proc. 34, part 2, 1934, pp. 354-386.
- 6) Domone, P.L., 1974. "Uniaxial Tensile Creep and Failure of Concrete." Magazine of Conc. Research, Vol. 26, no. 88, Sept. 1974, pp. 145, 151.
- 7) Elizzi, M.A., 1976. "The Time-Dependent Behaviour of some Evaporite Rocks." Ph. D. Thesis, Univ. of Sheffield, 1976.
- 8) Griggs, D.T., 1940. "Creep of Rocks." Journal of Geology, Col. 74, pp. 225-251.
- 9) Glanville, W.H., 1933. "Creep of Concrete under Load." The Structural Engineer I, No. 2, 1933, pp. 54-73.
- 10) Gopalakrishnan, K.S. Neville, A.M. and Ghali, A., 1969. "Creep Poisson's Ratio of Concrete under Multiaxial Compression." ACI, Journal, Proc. 66, 1969, 1008-2020.
- 11) Ilston, J.N., 1965. "The Components of Strain in Concrete under Sustained Compressive Stress." Magazine of Conc. Research, Vol. 17, No. 50, March, 1965, pp. 21-28
- 12) Ilston, J.N., 1965. "The Creep of Concrete under Uniaxial Tension." Magazine of Conc. Research, Vol. 51, June 1965, pp. 77-84.
- 13) Ilston, J.M. and Jordan, I.J., 1969. "The Creep of sealed Concrete under Multiaxial Compressive Stresses." Magazine of Conc. Research, Vol 21, No. 69, Dec. 1969, pp. 195, 204.
- 14) Ilston, J.M. and "Time-Dependent Strain in Sealed Concrete under Systems of Variable Multiaxial Stresses." Magazine of Conc. Research, Vol. 23, No. 75-76, 1971, pp. 79-93.
- 15) L'hermite, R., 1959. "What do we know about the plastic deformation and Creep of Concrete." RILEM Bull. no. 1, March 1959, pp. 21-51.
- 16) Lorman, W.R., 1940. "The Theory of Concrete Creep." ASTM Proc, 40, 1940, pp. 1082-1101.
- 17) Misra A.K., 1962 "An Investigation of Time-Dependent Deformation or 'Creep' in Rocks." Ph. D. Thesis, Univ. of Sheffield, 1962.
- 18) Murrell, S.A.F., 1962. "The Effect of the Triaxial Stress System on Strength of Brittle Materials with particular Reference to Rock." Ph. D. Thesis, Univ. of sheffield, 1962.
- 19) Neville, A.M., 1960. "Recovery of Creep and Observations on the Mechanism of Creep and Observations on the Mechanism of Concrete." Applied Sci. Research, Section A. Vol. 9, 1960, pp. 71-84.
- 20) Neville, A.M., 1970. "Creep of Concrete : Plain, Reinforce and Prestressed." North-Holland Publishing Co., Amsterdam 1970, p. 622.
- 21) Neville, A.M. and Brooks, j.j., 1977. "A Comparison of Creep, Elasticity and Strength of Concrete in Compression." Magazine Conc. Research, Vol. 29, No. 100, Sept. 1977, pp. 13-141.
- 22) Ruetz, W., 1965. "A Hypothesis for the Creep of Hardened Cement Paste and the influence of Simultaneous shrinkage. The Structure of Concrete and its behaviour under Load." Proc. of Int. Conf. London. Sept. 1965.
- 23) Rusch, H., 19603 "Researches Toward a General Flexural Theory for Structural Concrete." J. Amer. Conc. Inst., Proc. Vol. 57, no. 1, July 1960, pp. 1-28.
- 24) Sangha, C.N., 1972. "Strength, Deformation and Fracture Properties of Rock and Concrete." Ph. D. Thesis, Univ of Dune 1972.

- 25) Ruetz, W., 1965. "A Hypothesis for the Creep of Hardened Cement Paste and the influence of Similtaneous shrinkage. The Steucture of Concrete and its behaviour under Load." Proc. of Int. Conf. London, Sept. 1965.
- 26) Williama, F.T., and Elizzi, N.A., 1977. "Creep Properties of Sherburn Gypsum under Triaxial Loading." Proc. Conf. on Rock Engg., British Geotechnical Soc., April 1977, pp. 70–83.
- 27) Milliams, F.R. and Elizzi, M.A., 1976 "An Apparatus for the Deformation of Time Dependent behaviour of rocks under Triaxial Loading." Int. J. Rckk Mech. Min. Sci., Vol. 13, pp. 245–248
- 28) Ulitskii, I.I., 1962. "A Method of Computing Creep and Shrinkage Deformation of Concrete for Practical Purpose." Beton I Zhelezobeton, No. 4, 1962, pp. 174–180.
- 29) Wagner, O., 1958. "Creep of Plain Concrete," Deutsche Ausschuss fur Stah-Ibeton, No. 131, 1958, pp.74.
- 30) Williams, F.T., 1973. "LLYSYFRAN Reservoir : Refort on Laboratory Creep Testing of Concrete." Dept. of Civil and Structural Engineering, Univ. of Sheffield, Nov, 1973.

K C I